

STEREO CONTROL AMPLIFIER

CENTER

C-80

SERVICE MANUAL

FRONT PANEL

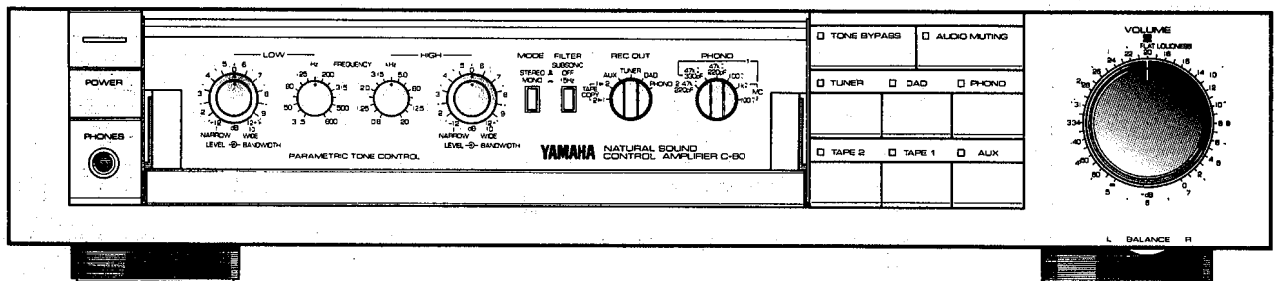

CAUTION:

The bus bar used in the PC board for this unit serves not only as a ground, but also for +B and -B power sources. Please take care when taking readings.

CONTENTS

TO SERVICE PERSONNEL	1
REAR PANEL	1
BLOCK DIAGRAM	2
SPECIFICATIONS	2
INTERNAL VIEW	3
DISASSEMBLY PROCEDURES	3
ADJUSTMENTS	3
PRINTED CIRCUIT BOARD	4~9
SCHEMATIC DIAGRAM	10
WIRING	11
PARTS LIST	12

004558

SINCE 1887



YAMAHA

NIPPON GAKKI CO., LTD. HAMAMATSU, JAPAN

2.6k-562 Printed in Japan. '84.6

C-80

TO SERVICE PERSONNEL

- Critical Components Information.**
Components having special characteristics are marked Δ and must be replaced with parts having specifications equal to those originally installed.
- Leakage Current Measurement (For 120V Model Only).**
When service has been completed, it is imperative that you verify that all exposed conductive surfaces are properly insulated from supply circuits.
 - Meter impedance should be equivalent to 1500 ohm shunted by 0.15 μ F.
 - Leakage current must not exceed 0.5mA.
 - Be sure to test for leakage with the AC plug in both polarities.

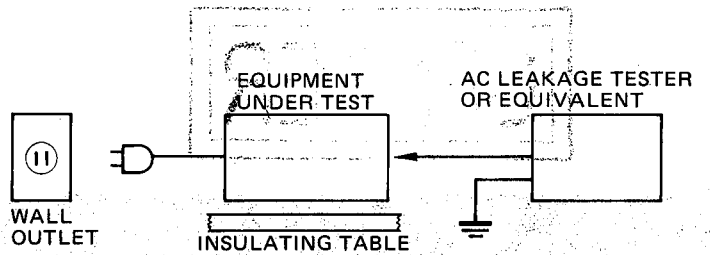

REAR PANEL

U.S.A. & Canadian models

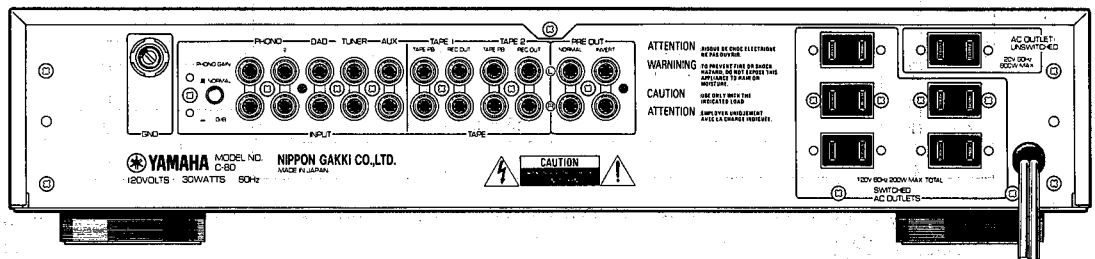

General model

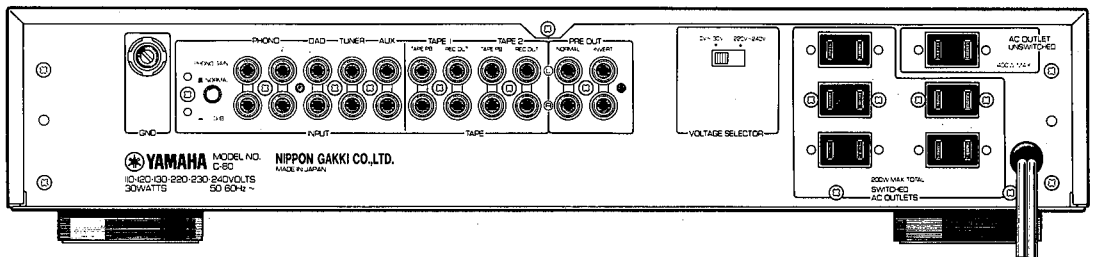

European model

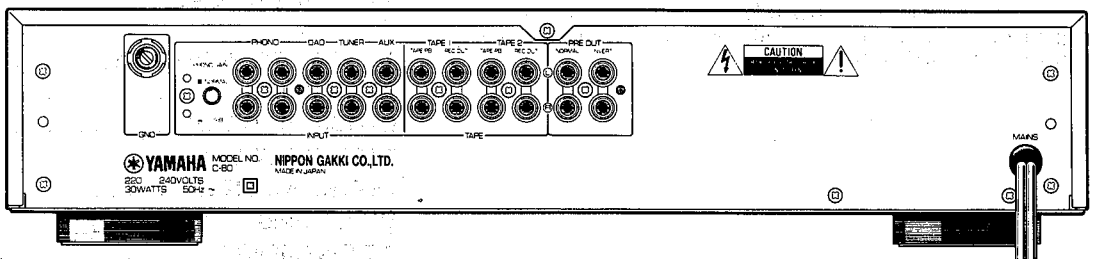

Australian model

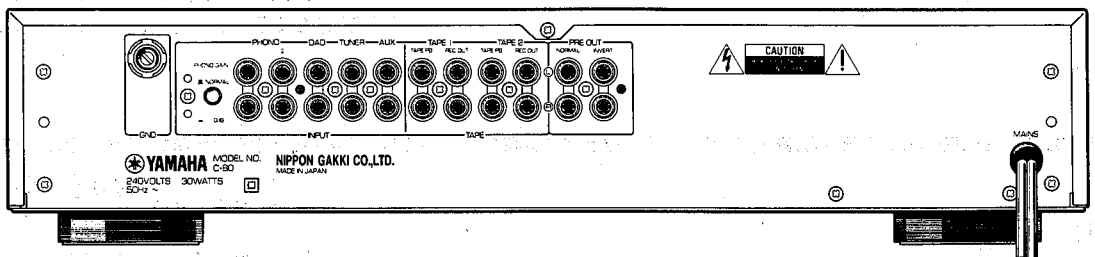

BLOCK DIAGM

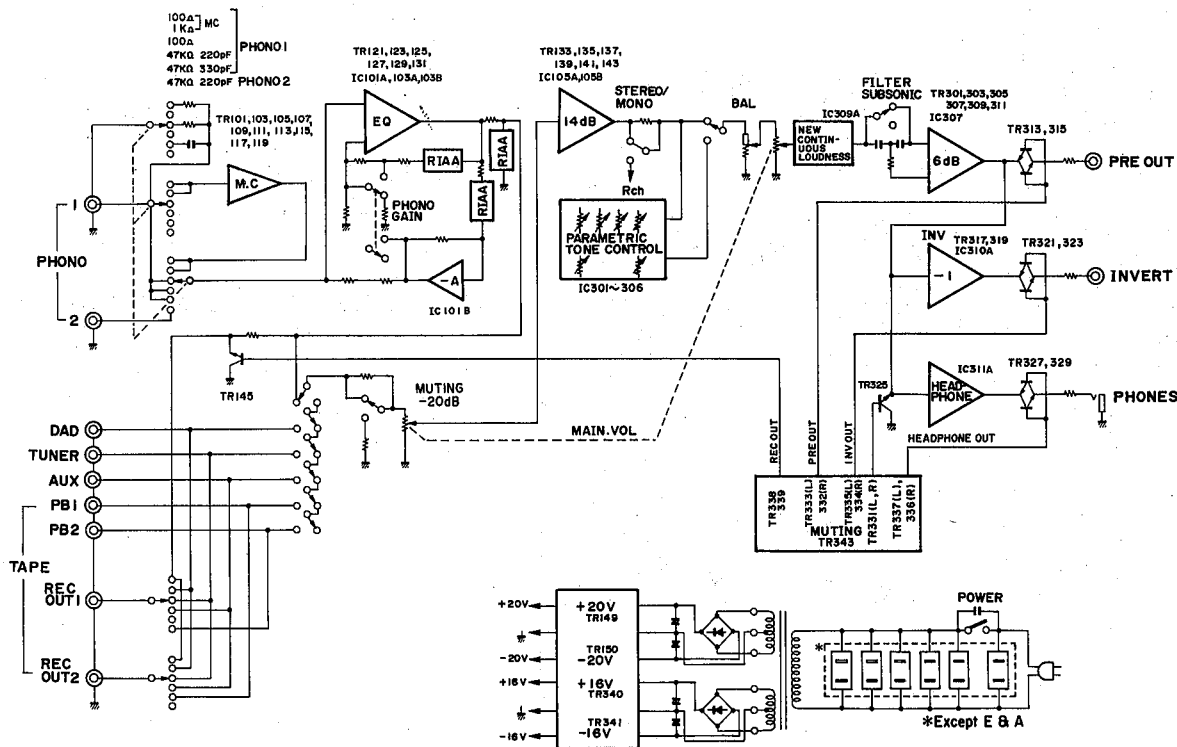

SPECIFICATIONS

Input Sensitivity/Impedance	
Phono 1 MC	100 μ V/100 Ω , 1k Ω
MM	2.5mV/100 Ω , 47k Ω (220P, 330P)
Phono 2 MM	2.5mV/47k Ω , (220P)
DAD, Aux, Tape, Tuner	150mV/47k Ω
Input Sensitivity (New IHF)	
Phono MC	33 μ V
MM	0.83mV
DAD, Aux, Tape, Tuner	50mV
Maximum-Input Signal (1kHz, 0.01% THD)	
Phono MC	20mV
MM	500mV
Output Level/Impedance	
Rec Out	150mV/600 Ω
Pre Out	1.5V/47 Ω
Maximum Voltage Output	
20Hz ~ 20kHz 1% THD	
Pre Out	8.5V
Headphone Jack Rated Output/Impedance	
0.01% THD 1kHz	6V/100 Ω
Frequency Response (Tone Bypass ON)	
DAD, Aux, Tape, Tuner 20Hz ~ 20kHz	+0 dB -0.2
RIAA Equalization Deviation	
Phono MC/MM 20Hz ~ 20kHz	\pm 0.2dB
Phono MM/MM 10Hz ~ 100kHz	\pm 0.5dB
Total Harmonic Distortion	
Phono MC to Rec Out 3V	0.001%
Phono MM to Rec Out 3V	0.001%
DAD, Aux, Tape, Tuner to Pre Out 3V (Tone Bypass ON)	0.001%
Intermodulation Distortion (Tone Bypass ON)	
DAD, Aux, Tape, Tuner 5V output	0.002%
Signal to Noise Ratio (IHF-A-Network)	
Phono MC (500 μ V Input Shorted)	91dB
Phono MM (5mV Input Shorted)	95dB
DAD, Aux, Tape, Tuner (Tone Bypass ON, 150mV Input Shorted)	106dB
Signal to Noise Ratio (New IHF)	
Phono MC	81dB
MM	83dB
DAD, Aux, Tape, Tuner	103dB

Residual Noise (IHF-A-Network)	1.5 μ V
Channel Separation	
Phono MM (Input Short) 40Hz	85dB
1kHz	80dB
10kHz	70dB
Aux, Tape (5.1k Ω) 40Hz	85dB
1kHz	70dB
10kHz	50dB
Parametric Tone Control	
Frequency Low	31.5Hz ~ 800Hz
High	800Hz ~ 20kHz
Level Low, High	\pm 12dB
Bandwidth Low, High	Q 0.3 ~ 3.0
Filter Characteristics	
Subsonic	15Hz, -12dB/oct
Continuous Loudness Control (Level-related equalization)	
Attenuation	40dB (1kHz)
Audio Muting	
	-20dB
Gain Tracking Error (0 ~ -60dB)	
	2dB
Power Supply	
U.S.A. & Canadian models	120V AC, 60Hz
General model	110 ~ 130V AC/220 ~ 240V AC 50/60Hz
European model	220 ~ 240V AC, 50Hz
Australian model	240V AC, 50Hz
Power Consumption	
	30W
AC Outlet (U.S.A., Canadian and General models)	
Switched x 5	200W max
Unswitched x 1	800W max (U, C) 400W max (R)
Dimensions (W x H x D)	
	435 x 95 x 380 mm (17-1/8" x 3-3/4" x 14-15/16")
Weight	
	6.8kg (14 lbs. 15 oz.)

Specifications subject to change without notice.

- (U) .. U.S.A. model
- (C) .. Canadian model
- (A) .. Australian model
- (E) .. European model
- (R) .. General model

INTERNAL VIEW

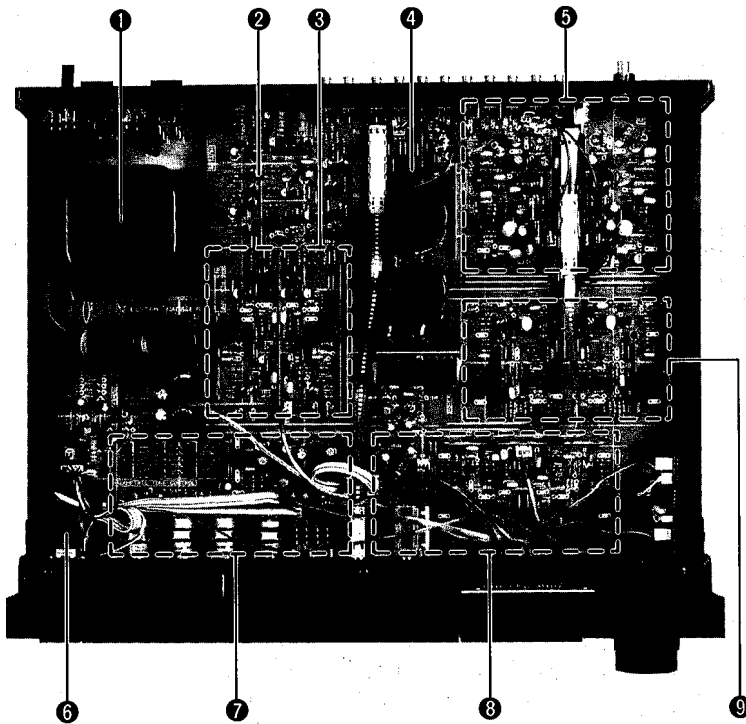

- ① POWER TRANSFORMER
General model: GA67540
U.S.A. & Canadian models: GA67550
Australian & European models: GA67880
- ② TONE CONTROL CIRCUIT BOARD
- ③ 6dB FLAT AMP SECTION
- ④ EQUALIZER CIRCUIT BOARD
- ⑤ MC AMP SECTION
- ⑥ POWER SWITCH
- ⑦ PARAMETRIC TONE CONTROL SECTION
- ⑧ 14dB FLAT AMP SECTION
- ⑨ EQ AMP SECTION

DISASSEMBLY PROCEDURES

(Remove parts in order to disassemble as numbered)

1. Removal of Top Cover

- a. Remove 5 screws (①) in Fig. 1.

2. Removal of Bottom Cover

- a. Remove 8 screws (②) in Fig. 1.

3. Removal of Panel Unit

- a. Remove the knobs.

NOTE: Remove the VOL. and LOUD. knobs by hexagon 1inch 2mm or 5/64".

- b. Remove 8 screws (③) in Fig. 1.

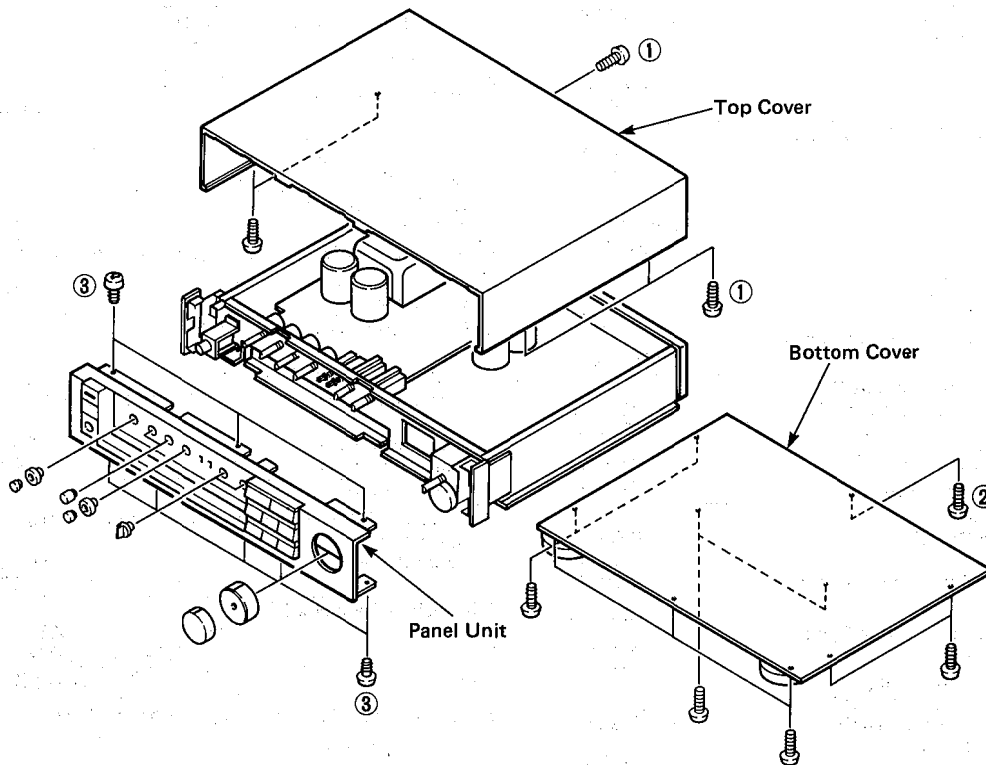

Fig. 1

ADJUSTMENTS

BEFORE COMMENCING

1. Make sure that primary supply voltage comes within *120V AC \pm 10% (U, C models).
2. Proceed with the adjustments about 5 minutes after the power has been turned on to stabilize the operation of the amplifier.

* E model 220V AC.
A model 240V AC.

- Set the controls to the following positions.

PHONO \rightarrow MC
REC OUT \rightarrow PHONO

Adjustment item	Test point	Instrument required	Adjustment points	Rating
MC AMP DC offset	REC OUT	DCVM	VR101 (Lch) VR102 (Rch) [EQUALIZER]	0V \pm 100mV

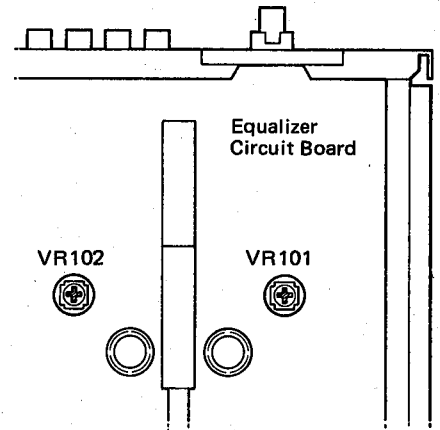
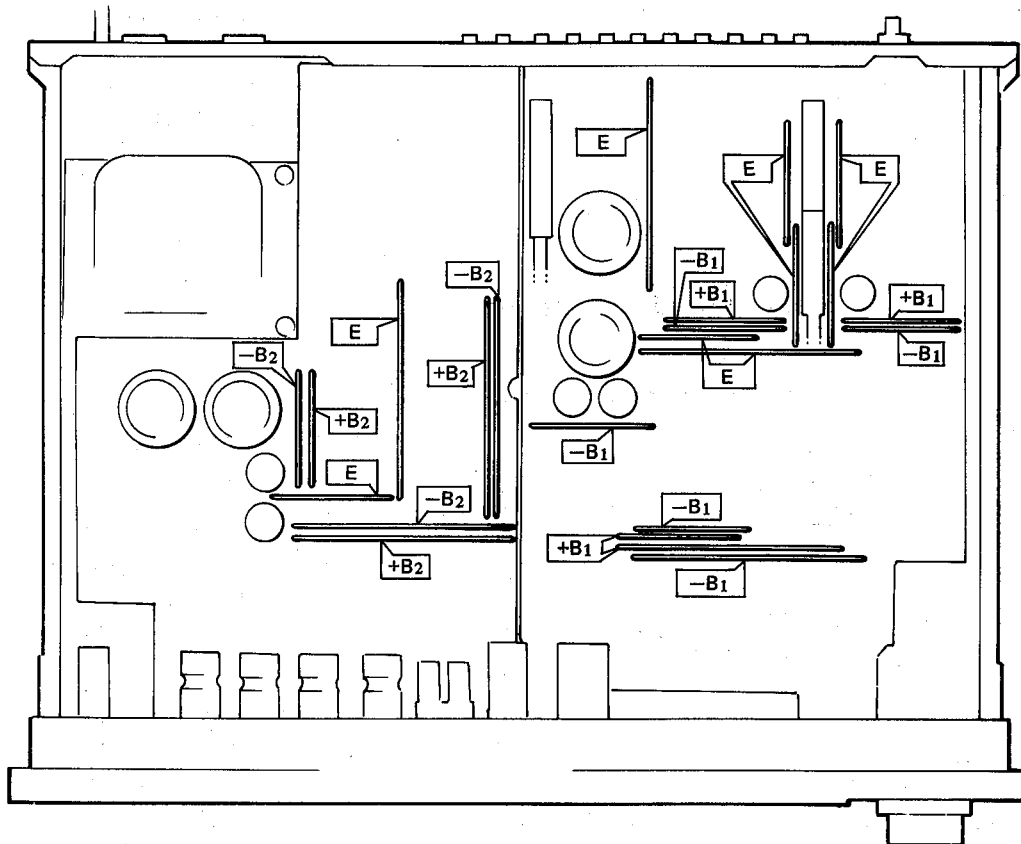

Fig. 2

CAUTION:

The bus bar used in the PC board for this unit serves not only as a ground, but also for +B and -B power sources. Please take care when taking readings.



+B1	+20V \pm 1V
-B1	-20V \pm 1V
+B2	+16V \pm 1V
-B2	-16V \pm 1V
E	GND