

213

STEREO POWER AMPLIFIER MX-1000/U

SERVICE MANUAL

MX-1000/U

IMPORTANT NOTICE

This manual has been provided for the use of authorized Yamaha Retailers and their service personnel. It has been assumed that basic service procedures inherent to the industry, and more specifically Yamaha Products, are already known and understood by the users, and have therefore not been restated.

WARNING: Failure to follow appropriate service and safety procedures when servicing this product may result in personal injury, destruction of expensive components and failure of the product to perform as specified. For these reasons, we advise all Yamaha product owners that all service required should be performed by an authorized Yamaha Retailer or the appointed service representative.

IMPORTANT: The presentation or sale of this manual to any individual or firm does not constitute authorization, certification or recognition of any applicable technical capabilities, or establish a principle-agent relationship of any form.

The data provided is believed to be accurate and applicable to the unit(s) indicated on the cover. The research, engineering, and service departments of Yamaha are continually striving to improve Yamaha products. Modifications are, therefore, inevitable and specifications are subject to change without notice or obligation to retrofit. Should any discrepancy appear to exist, please contact the distributor's Service Division.

WARNING: Static discharges can destroy expensive components. Discharge any static electricity your body may have accumulated by grounding yourself to the ground buss in the unit (heavy gauge black wires connect to this buss).

IMPORTANT: Turn the unit OFF during disassembly and parts replacement. Recheck all work before you apply power to the unit.

■ CONTENTS

TO SERVICE PERSONNEL	1	DISASSEMBLY PROCEDURES	5
SPECIFICATIONS	1	ADJUSTMENTS	5
FRONT PANELS	2	PRINTED CIRCUIT BOARD	6 ~ 13
REAR PANELS	3	SCHEMATIC DIAGRAM	14
BLOCK DIAGRAM	4	WIRING	15
INTERNAL VIEW	4	PARTS LIST	16 ~ 24

TO SERVICE PERSONNEL

- Critical Components Information.**
Components having special characteristics are marked Δ and must be replaced with parts having specifications equal to those originally installed.
- Leakage Current Measurement (For 120V Model Only).**
When service has been completed, it is imperative that you verify that all exposed conductive surfaces are properly insulated from supply circuits.
 - Meter impedance should be equivalent to 1500 ohm shunted by 0.15 μ F.
 - Leakage current must not exceed 0.5mA.
 - Be sure to test for leakage with the AC plug in both polarities.

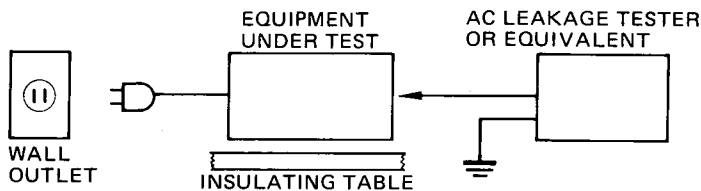

POLARIZATION (U, C models only)

This amplifier product is equipped with a polarized alternating current line plug (a plug having one blade wider than the other). This plug will fit into the power outlet only one way. This is a safety feature.

SPECIFICATIONS

Minimum RMS Output Power per Channel	
20Hz ~ 20kHz	
0.003% THD, 8 Ω	260W
0.007% THD, 6 Ω	295W
0.02% THD, 4 Ω	330W
Dynamic Power per Channel (by IHF Dynamic Headroom measuring method)	
8 Ω	450W
6 Ω	560W
4 Ω	740W
2 Ω	960W
1 Ω	1000W
DIN Standard Output Power per Channel	
1kHz, 1% THD, 4 Ω	450W (G)
Dynamic Headroom	
8 Ω	2.38dB (U, C, R)
6 Ω	2.78dB (U, C, R)
4 Ω	3.51dB (U, C, R)
IEC Power (1kHz, 0.01% THD)	
8 Ω	315W (G)
6 Ω	375W (G)
4 Ω	440W (G)
Power Band Width	
0.03% THD, 130W, 8 Ω	10kHz ~ 60kHz
Damping Factor	
8 Ω , 1kHz	130
Input Sensitivity/Impedance	
MAIN IN	1.62V/60k Ω
Frequency Response (20Hz ~ 20kHz)	
MAIN IN	+0, -0.2dB
Total Harmonic Distortion	
20Hz ~ 20kHz	
MAIN IN TO SP OUT (130W/8 Ω)	0.003%
Intermodulation Distortion	
Rated Output /8 Ω	0.003%
Signal to Noise Ratio (IHF-A Network)	
MAIN IN (Shorted)	126dB
MAIN IN (5.1k Ω terminated)	122dB
Residual Noise (IHF-A Network)	
	21 μ V
Channel Separation (Vol. -30dB)	
Input Shorted (1kHz/10kHz)	89dB/72dB
Power Supply	
	AC220/240V, 50Hz (B, G)
	AC110/120/220/240V, 50/60Hz (R)
	AC240V, 50Hz (A)
	AC120V, 60Hz (U, C)

Power Consumption	1100W, 1300VA (U, C) 850W (R) 1700W (A, B, G)
AC Outlet	Un Switched x 1
	200W max. (U, C, R)
Dimensions (W x H x D)	435 x 170 x 425mm (17-1/8" x 6-11/16" x 16-3/4")
Weight	20.5kg (45 lbs 4 oz)

* Specifications are subject to change without notice.

- (U) U.S.A. Model
- (C) Canadian Model
- (A) Australian Model
- (B) British Model
- (G) European Model
- (R) General Model

DIMENSION

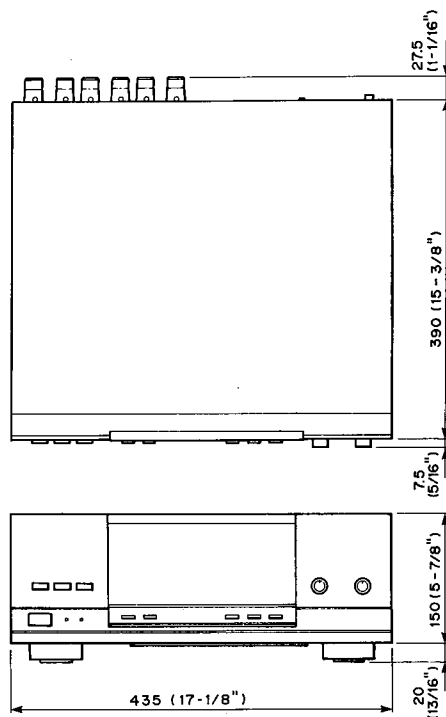

Unit: mm (inch)

MX-1000/U

FRONT PANELS

● MX-1000 (General, European, British & Australian models)

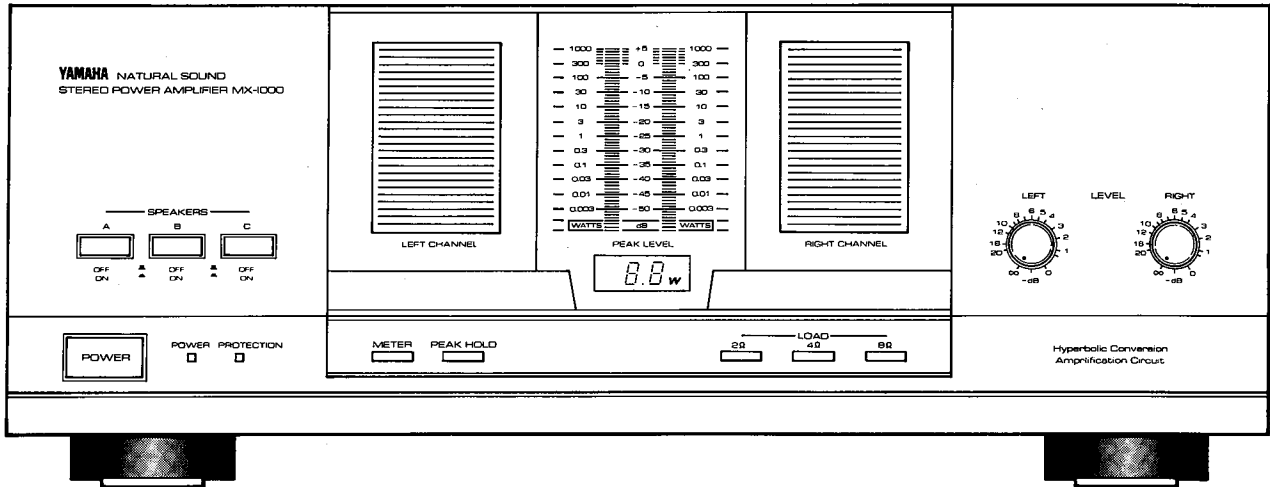

● MX-1000U (U.S.A. & Canadian models)

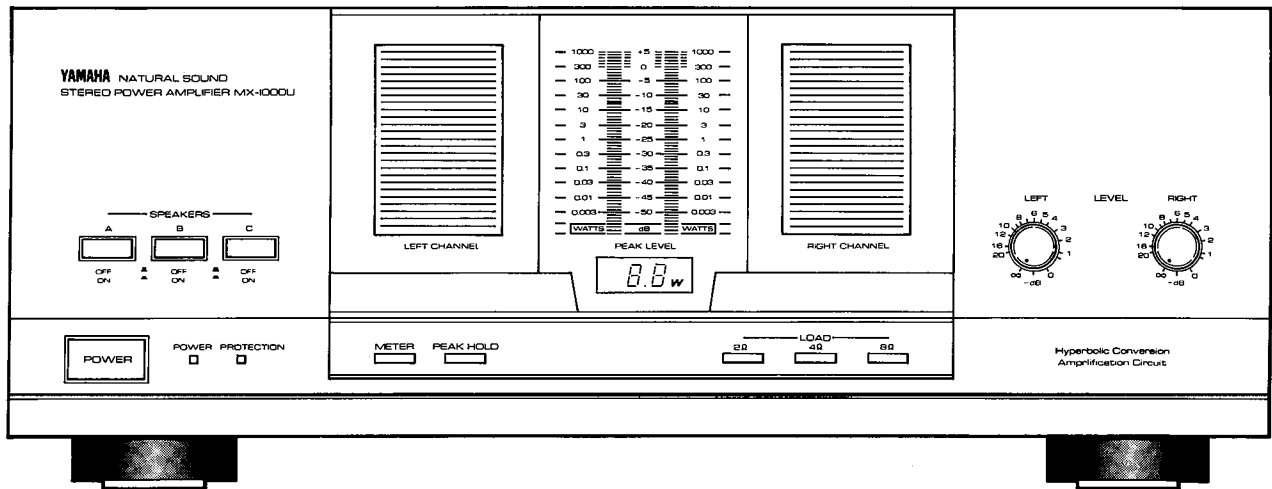

MX-1000/U

REAR PANELS

General model

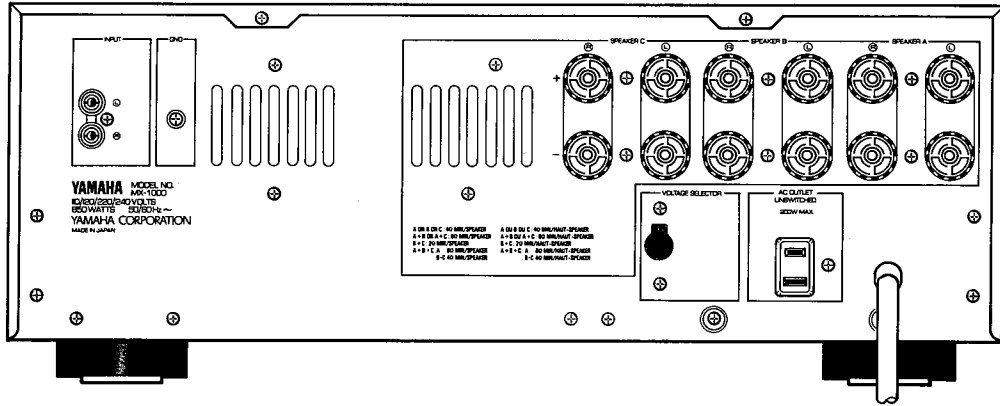

Australian model

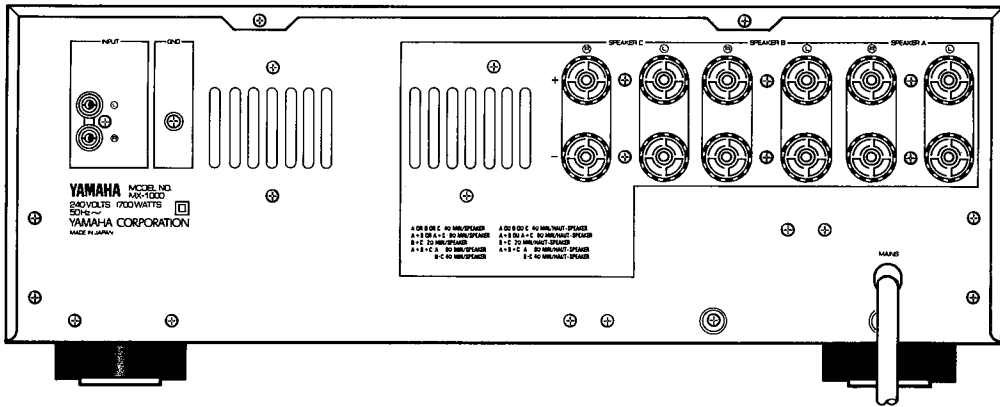

U.S.A. & Canadian models

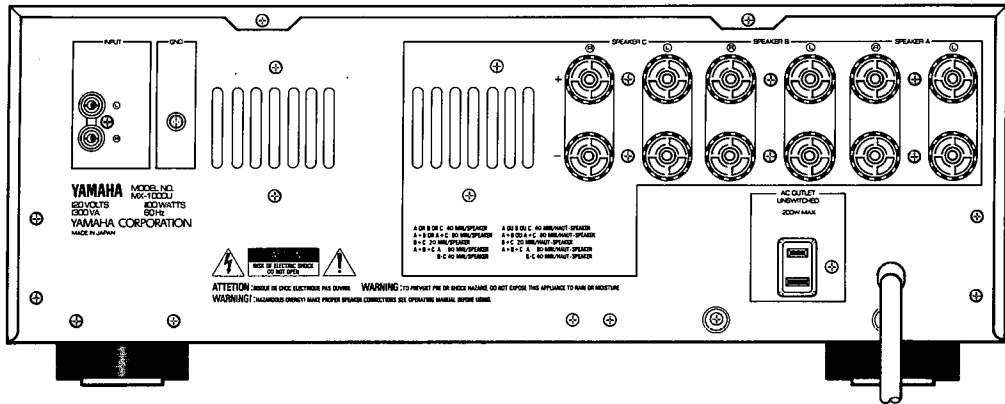

British & European models

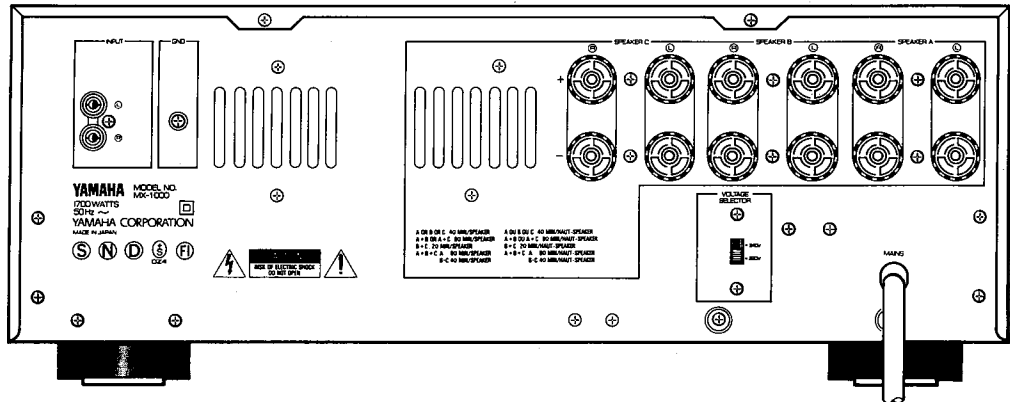

MX-1000/U

BLOCK DIAGRAM

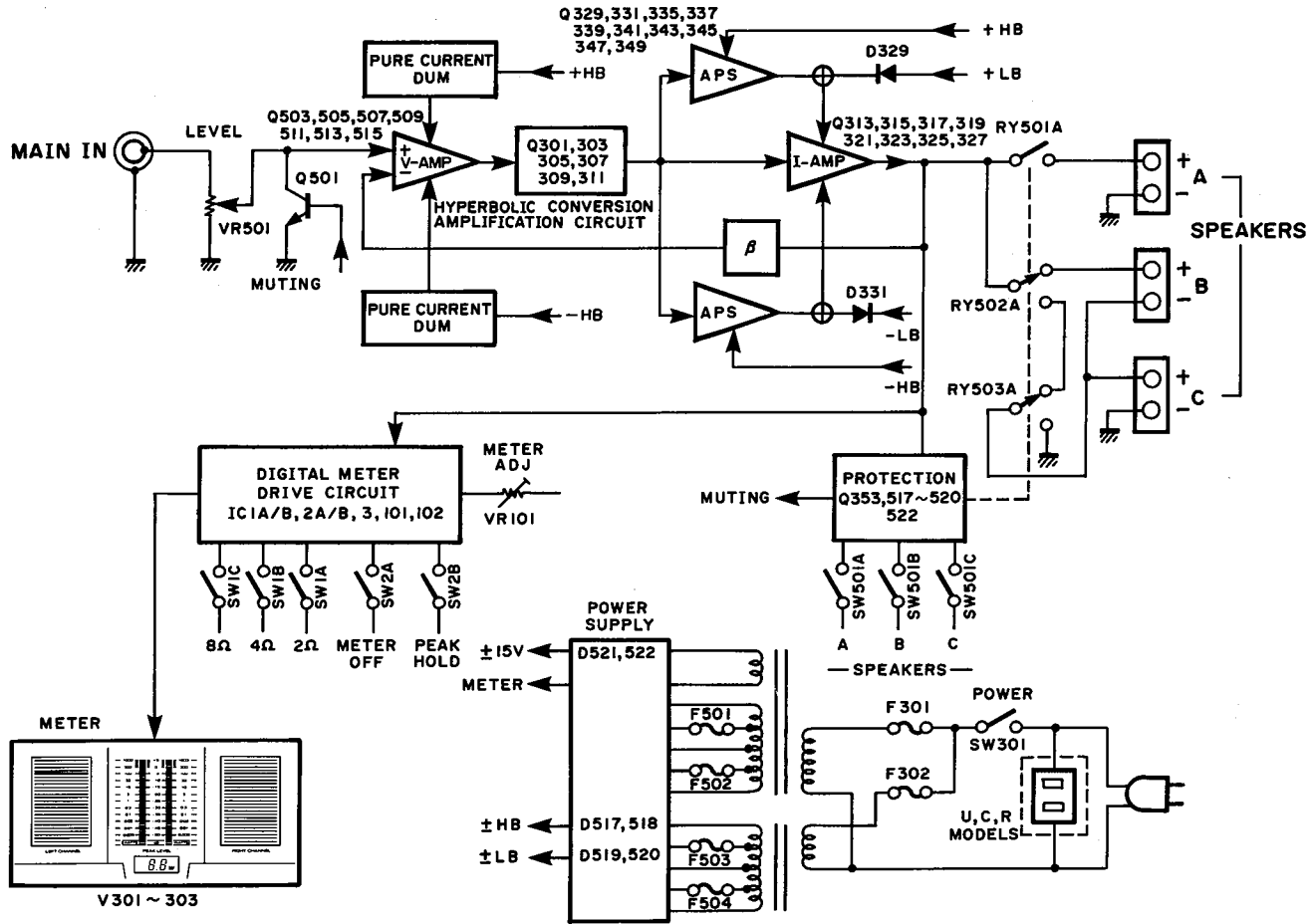

INTERNAL VIEW

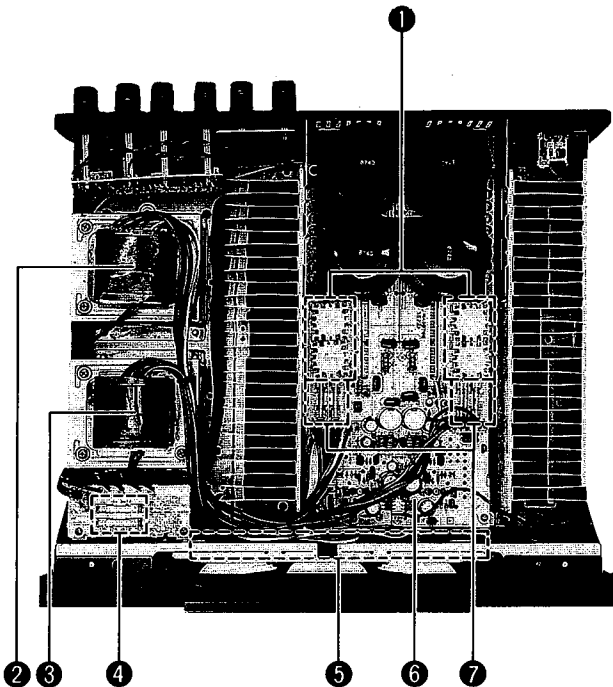

① DIODE BRIDGE : D5FB20
POWER TRANSFORMER

- U model : XE197001
- C model : XE199001
- R model : XE201001
- B, G models: XE203001
- A model : XE686001

③ POWER TRANSFORMER

- U model : XE196001
- C model : XE198001
- R model : XE200001
- B, G models: XE202001
- A model : XE685001

④ FUSE

- U, C models: 10A, 250V x 2
- A, B, G models: T4A, 250V x 2
- R models: 20A, 250V x 1

⑤ METER UNIT

⑥ MAIN CIRCUIT BOARD (1)

⑦ FUSE

- U, C, R models: 7A, 125V x 4
- A, B, G models: T6.3A, 250V x 4

MX-1000/U

DISASSEMBLY PROCEDURES

1. Removal of Top Cover.

Remove 6 screws (①) in Fig. 1. and slide the Top Cover back.

2. Removal of Bottom Cover.

Remove 6 screws (②) in Fig. 1.

3. Removal of Front Panel.

Remove 5 screws (③) in Fig. 1.

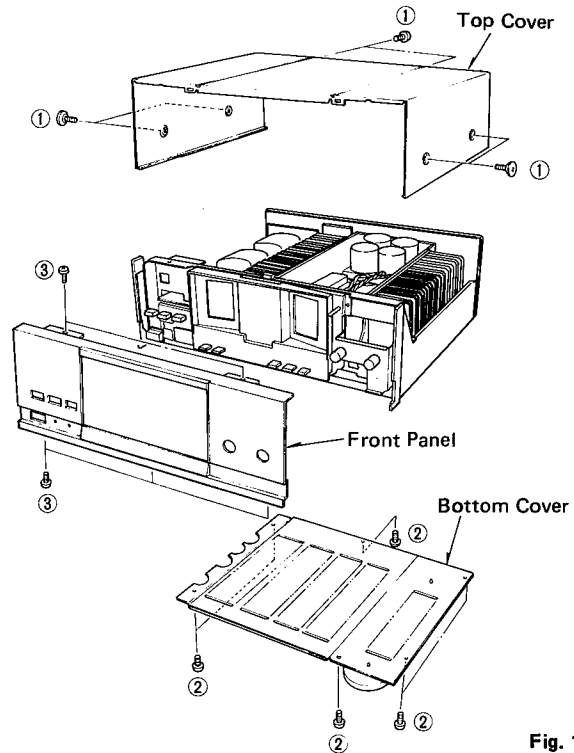

Fig. 1.

ADJUSTMENTS

• IDLING CURRENT ADJUSTMENT

Wait 2 minutes after power ON to stabilize amplifier operation without signal.

Adjust VR301 (Lch) and VR302 (Rch) so that the voltage across the terminals of R579 (Lch) and R578 (Rch) come to $10\text{mV} \pm 1\text{mV DC}$.

	Test Points	Adjustment Points	Rating
L ch	Across the terminals of R579	VR301	$10\text{mV} \pm 1\text{mV DC}$.
R ch	Across the terminals of R578	VR302	

• TEST POINTS

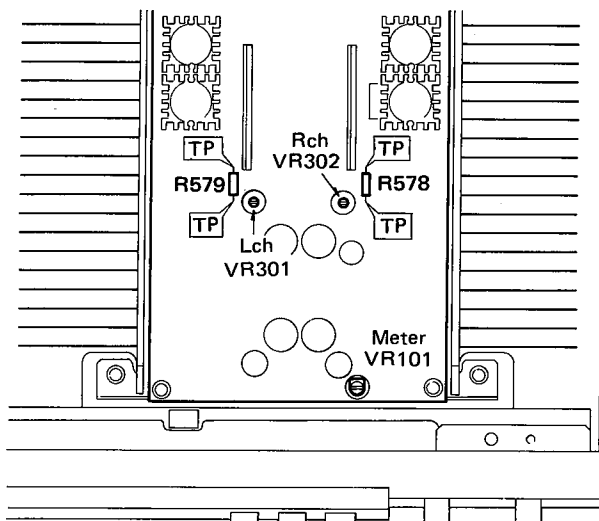

• METER LEVEL ADJUSTMENT

1) Set the controls to the following positions.

LOAD selector : 8Ω

Amplifier load : No load or 8Ω

PEAK HOLD switch : OFF

2) Apply a 1kHz sine wave signal from LINE IN so that SP. output voltage is 28.3V AC.

3) Adjust VR101 so that 99.3W of the digital meter display.

4) LOAD selector : 4Ω

Confirm that 199.W of the digital meter display.

5) Confirm that all segments fades out at no signal condition.

