

TC-WE425/WE525/ WR681

SERVICE MANUAL

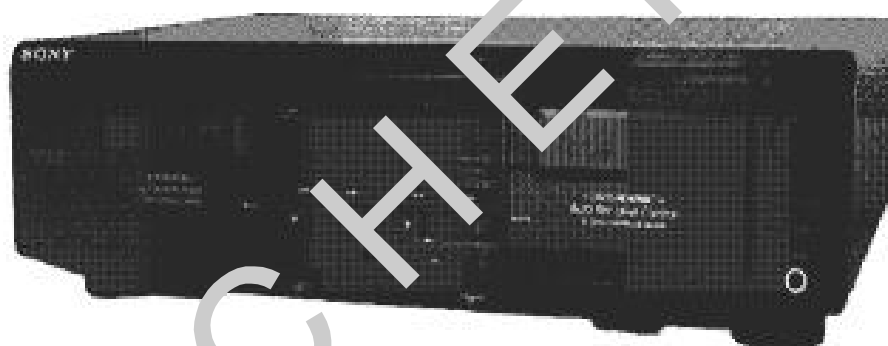

Photo: TC-WE425

US Model

TC-WE425/WR681

Canadian Model

TC-WE425

AEP Model

TC-WE525/WR681

UK Model

TC-WE525

E Model

Australian Model

TC-WE425/WR681

Chinese Model

TC-WE425

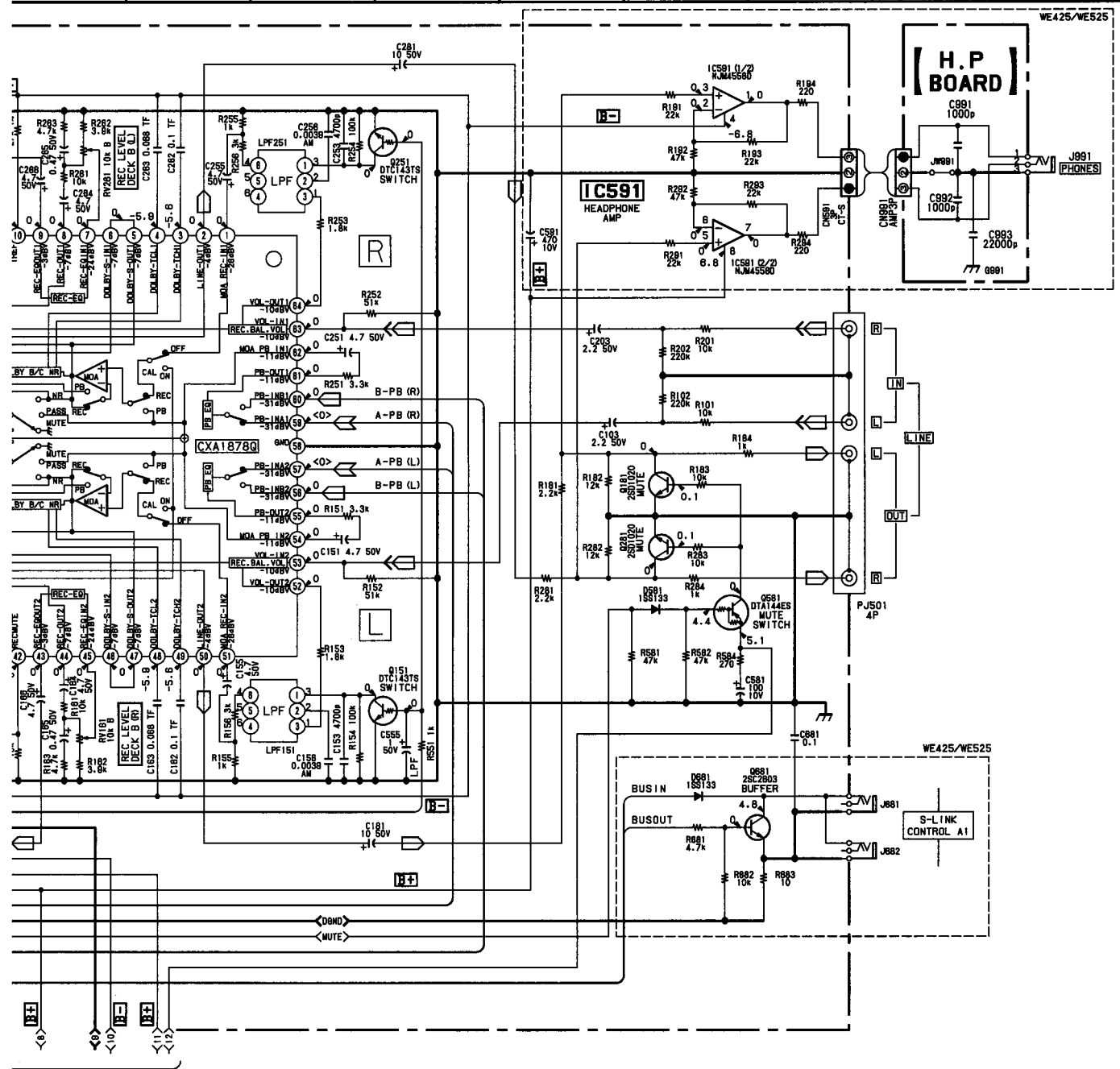

5-6. SCHEMATIC DIAGRAM — MAIN SECTION (3/3) —

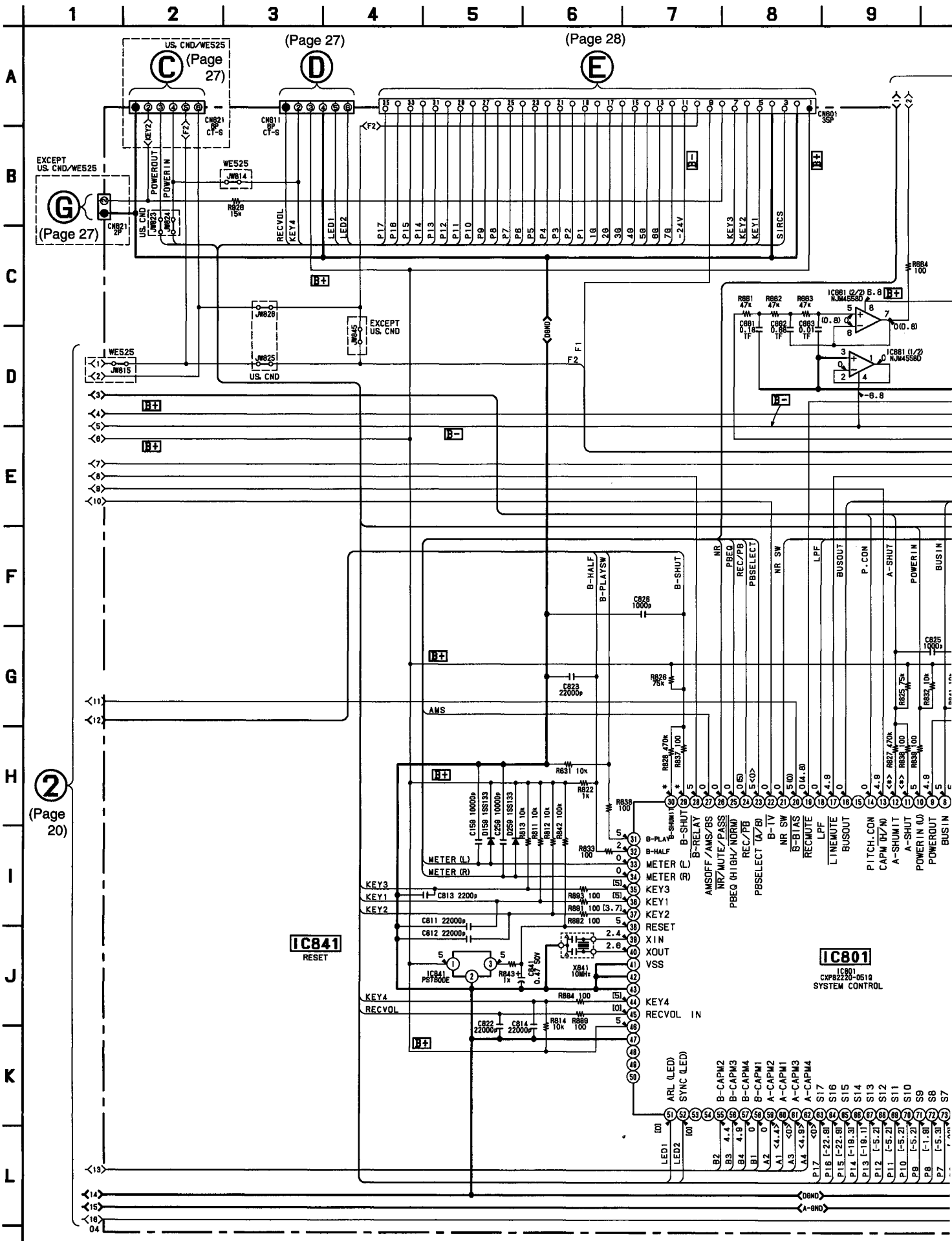

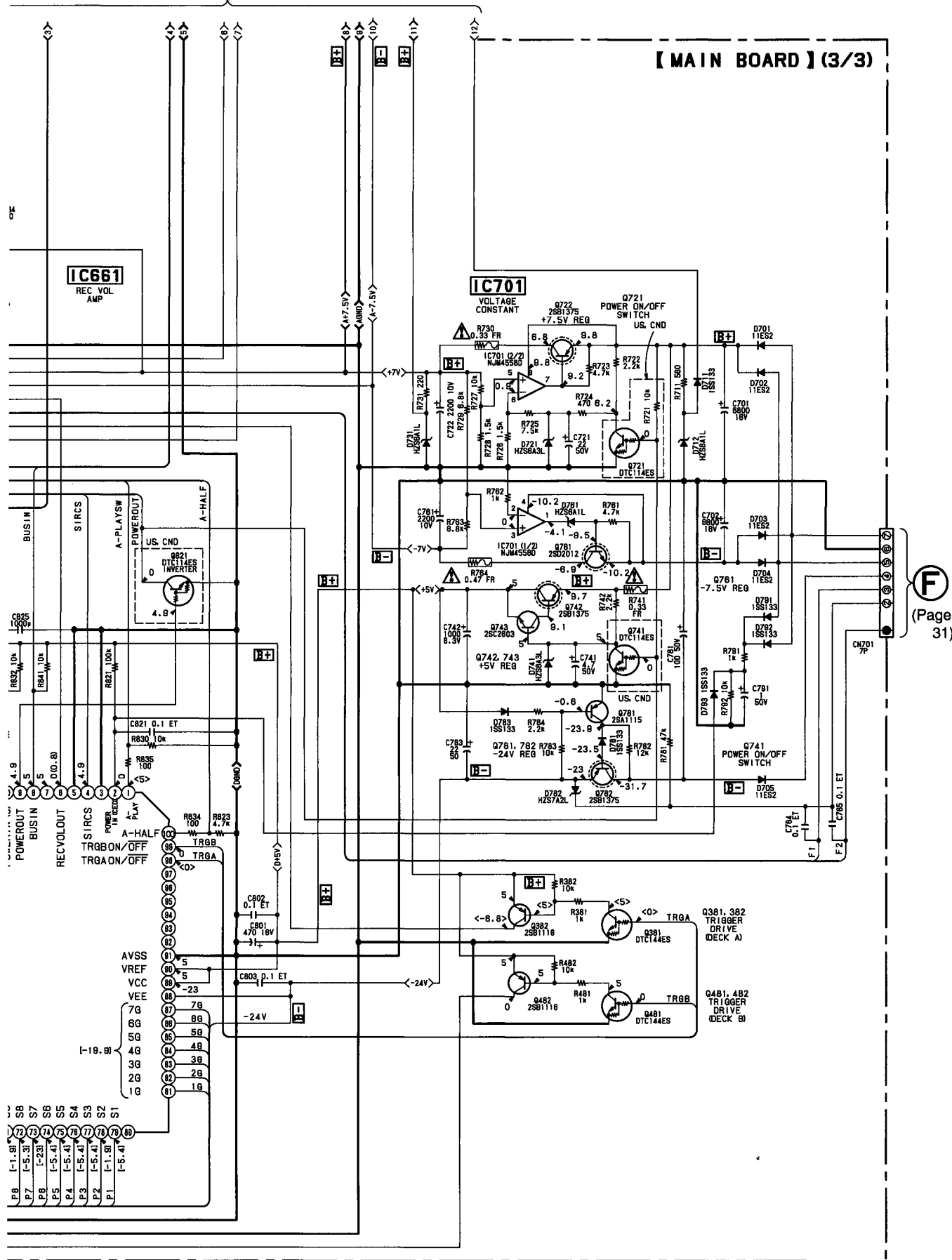

5-8. SCHEMATIC DIAGRAM — PANEL SECTION —

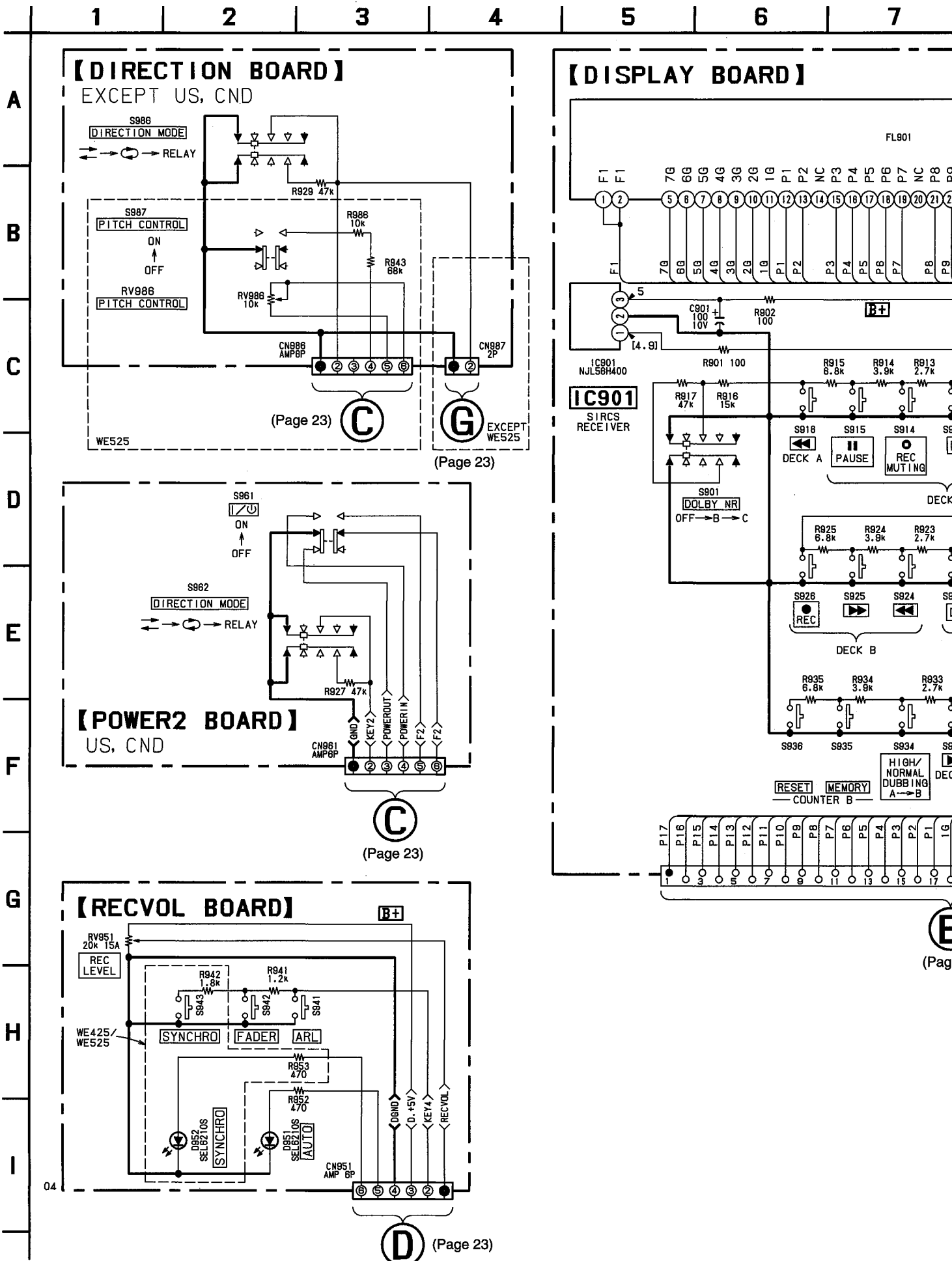

8

9

10

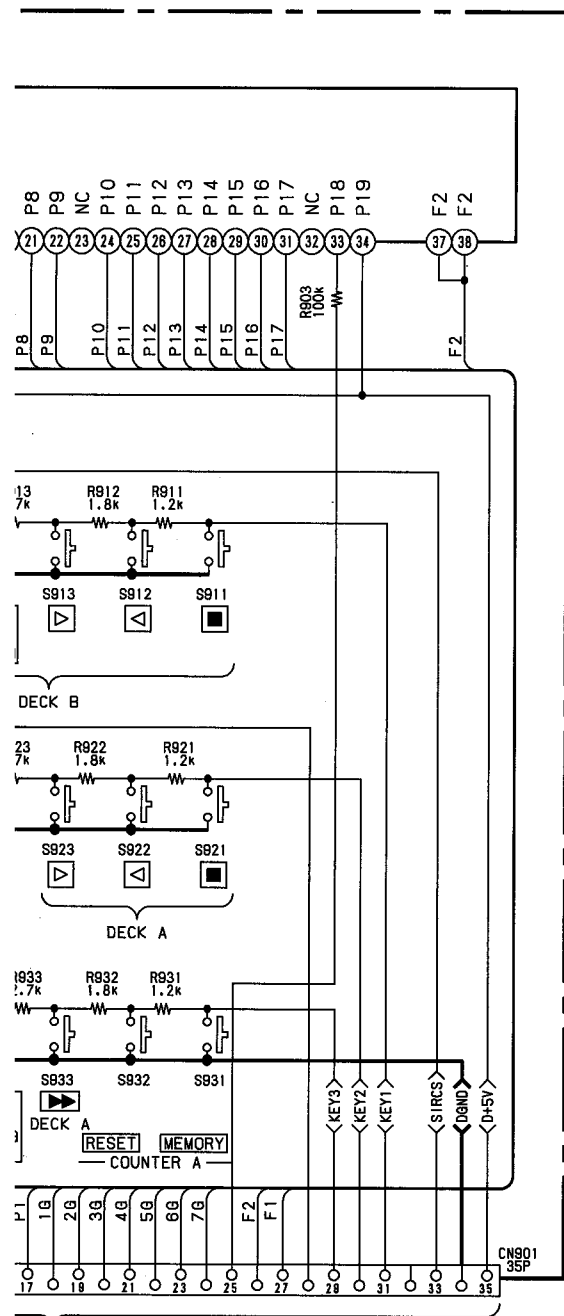

E

Page 23)

5-10. SCHEMATIC DIAGRAM — POWER SECTION —

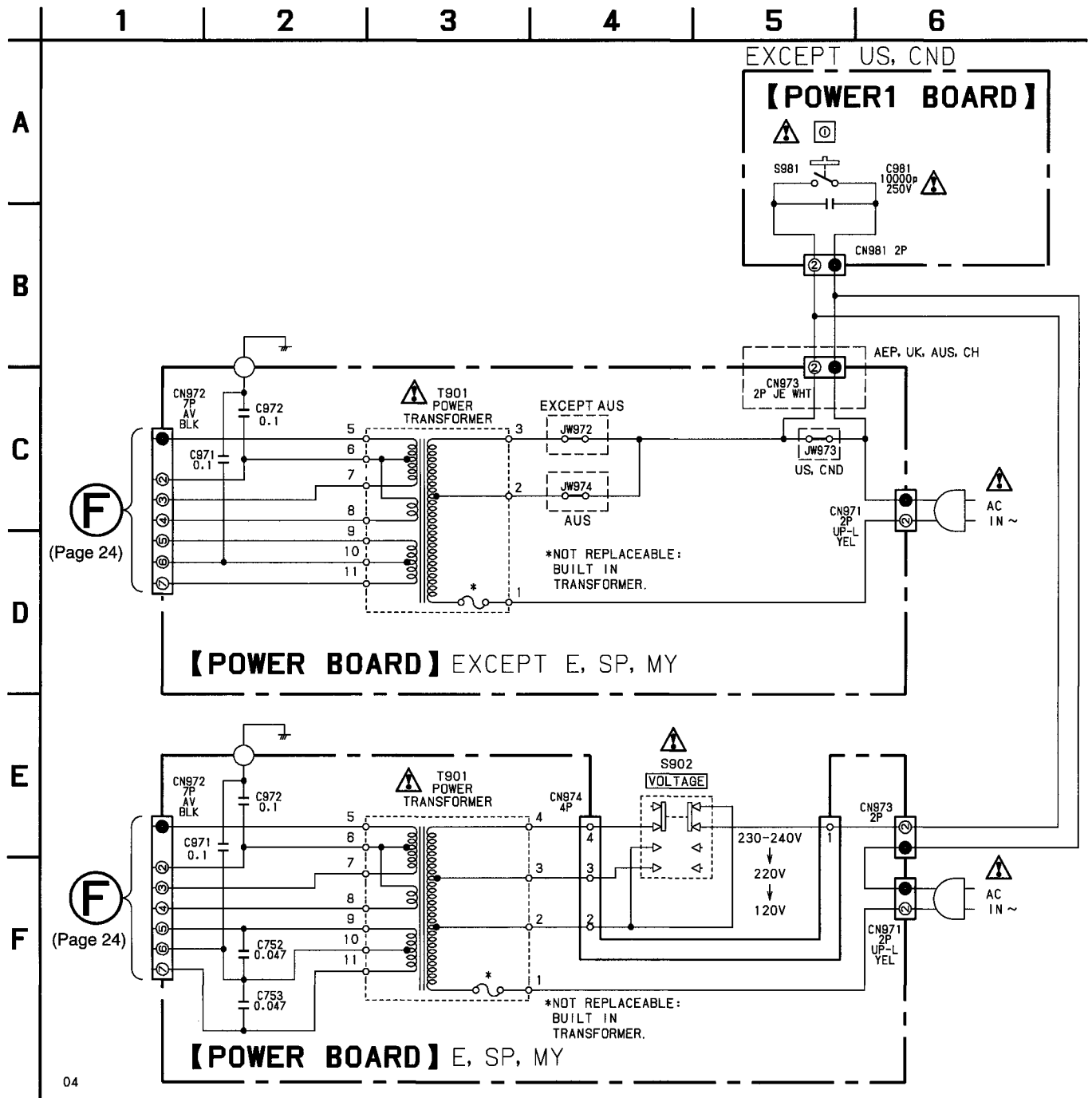

04

5-11. PRINTED WIRING BOARD — DECK A SECTION —

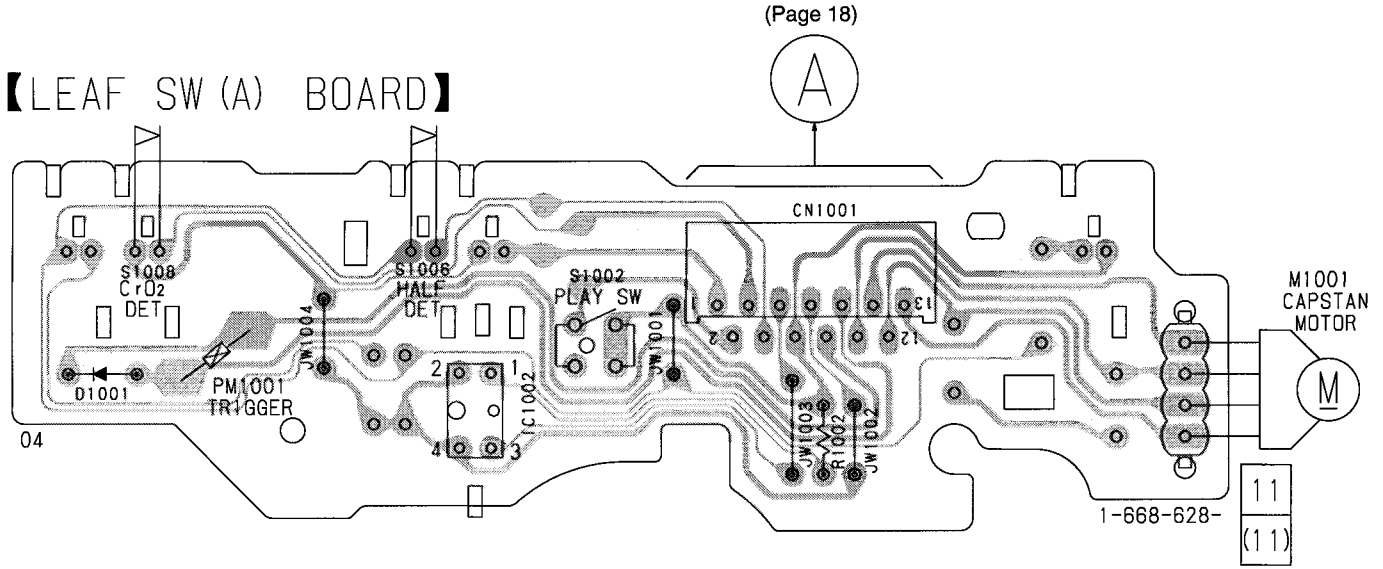

5-12. SCHEMATIC DIAGRAM — DECK A SECTION —

