

TC-WA7ESA/WE505/WE605S/ WE705S/WR550Z

SERVICE MANUAL



Photo : TC-WE705S

US Model
TC-WA7ESA/WE605S/WR550Z

Canadian Model
TC-WA7ESA/WE605S

AEP Model
TC-WE505/WE705S

UK Model
TC-WE505

E Model
Australian Model
Chinese Model
TC-WE605S

* Dolby noise reduction and HX Pro headroom extension manufactured under license from Dolby Laboratories Licensing Corporation. HX Pro originated by Bang & Olufsen.

"DOLBY", the double-D symbol $\square\square$ and "HX PRO" are trademarks of Dolby Laboratories Licensing Corporation.

Model Name Using Similar Mechanism		TC-WA7ES/WR565/WE665S
Tape Transport Mechanism Type	DECK-A	TC-WE605S/WR550Z : TCM-190RA12CL
		TC-WE505 : TCM-190RA14CL
		TC-WA7ESA : TCM-190RA17CL
		TC-WE705S : TCM-190RA18C
Tape Transport Mechanism Type	DECK-B	TC-WA7ESA/WE705S : TCM-190RB11C
		TC-WE505/WE605S/WR550Z : TCM-190RB12CL

SPECIFICATIONS

System

Recording system

4-track 2-channel stereo

Fast-winding time (approx.)

90 sec. (with Sony C-60 cassette)

High-speed fast-winding time (approx.) (TC-WA7ESA and TC-WE705S only)

45 sec. (with Sony C-60 cassette)

Bias

AC bias

Signal-to-noise ratio (at peak level and weighted with Dolby NR off)

Type I tape, Sony Type I (NORMAL): 55 dB

Type II tape, Sony Type II (HIGH): 57 dB

Type IV tape, Sony Type IV (METAL): 58 dB

S/N ratio improvement (approximate values)

With Dolby B NR on: 5 dB at 1 kHz, 10 dB at 5 kHz

With Dolby C NR on: 15 dB at 500 Hz, 20 dB at 1 kHz

With Dolby S NR on (unavailable on the TC-WE505):

10 dB at 100 Hz, 24 dB at 1 kHz

Harmonic distortion

0.4% (with Type I tape, Sony Type I (NORMAL):
160 nWb/m 315 Hz, 3rd H.D.)

1.8% (with Type IV tape, Sony Type IV (METAL):
250 nWb/m 315 Hz, 3rd H.D.)

Frequency response (Dolby NR off)

Tape type

Type I tape, Sony Type I (NORMAL) 30 - 16,000 Hz (± 3 dB, IEC),
20 - 17,000 Hz (± 6 dB)

Type II tape, Sony Type II (HIGH) 30 - 17,000 Hz (± 3 dB, IEC),
20 - 18,000 Hz (± 6 dB)

Type IV tape, Sony Type IV (METAL) 30 - 19,000 Hz (± 3 dB, IEC),
20 - 20,000 Hz (± 6 dB),
30 - 13,000 Hz (± 3 dB, -4 dB recording)

— Continued on page 2 —



STEREO CASSETTE DECK
SONY

SECTION 3 ADJUSTMENTS

3-1. MECHANICAL ADJUSTMENTS

PRECAUTION

- Clean the following parts with a denatured alcohol-moistened swab:

record/playback/erase head	pinch roller
rubber belts	capstan
idlers	
- Demagnetize the record/playback head with a head demagnetizer.
- Do not use a magnetized screwdriver for the adjustment.
- After the adjustments, apply suitable locking compound to the parts adjusted.
- The adjustments should be performed with the rated power supply voltage unless otherwise noted.

Torque Measurement

Torque	Torque meter	Meter reading
Forward	CQ-102C	30 to 65g • cm (0.42 to 0.9 oz • inch)
Forward back tension	CQ-102C	DECK-A : 1 to 6g • cm (0.014 to 0.083 oz • inch) DECK-B : 2 to 9g • cm (0.03 to 0.12 oz • inch)
Reverse	CQ-102RC	30 to 65g • cm (0.42 to 0.9 oz • inch)
Reverse back tension	CQ-102RC	1 to 6g • cm (0.014 to 0.083 oz • inch)
FF/REW	CQ-201B	70 to 120g•cm (0.98 to 1.66 oz•inch)

3-2. ELECTRICAL ADJUSTMENTS

PRECAUTION

- The adjustment should be performed in the publication.
(Be sure to make playback adjustment at first.)
- The adjustments and measurement should be performed for both L-CH and R-CH.
 - Switch position
 - DOLBY NR switch : OFF
 - DIRECTION MODE switch : ⇄
 - Standard record position :
 - Deliver the standard input signal level to input jack and set the REC LEVEL control to obtain the standard output signal level as follows.

— Record Mode —

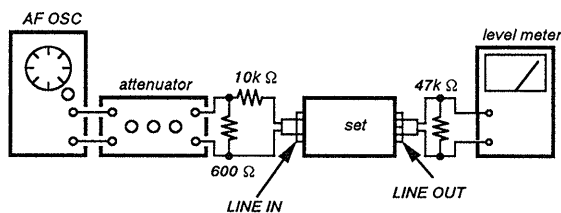

Standard Input Level

Input terminal	LINE IN
source impedance	10k Ω
input signal level	0.5V (- 3.8dB)

Standard Output Level

Output terminal	LINE OUT
load impedance	47k Ω
output signal level	0.5V (- 3.8dB)

Test Tape

Tape	Contents	Use
P-4-A100	10kHz, - 10dB	Azimuth Adjustment
P-4-L300	315Hz, 0dB	PB Level Adjustment
WS-48B	3kHz, 0dB	Tape Speed Adjustment

0dB=0.775V

Test Mode

- Insert a short-circuit plug into TP801 (2P) and turn ON the power switch.
At first, all the fluorescent tubes light up, then the system returns to normal display. (However, "0,00" is not displayed on the counter.)
- To release the test mode, remove the short plug and turn off the power switch.
- Remove the short plug after completion of adjustment.

Record/Playback Head Azimuth Adjustment

DECK-A **DECK-B**

Procedure :

- Forward playback Mode

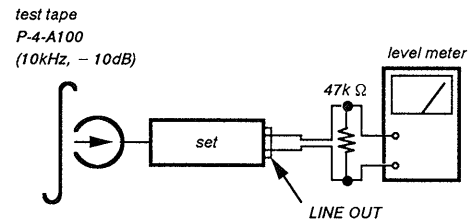

- Turn the adjustment screw for the maximum output levels. If these levels do not match, turn the adjustment screw until both of output levels match together within 1dB.

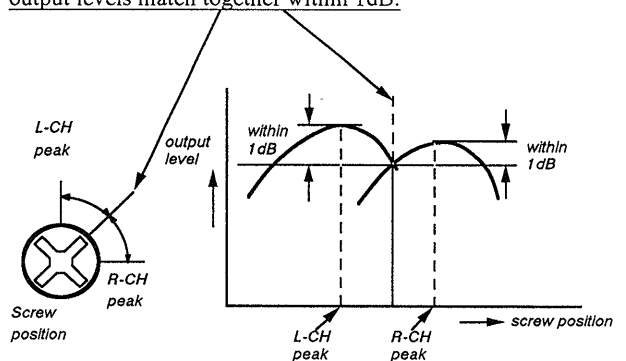

3. Playback Mode

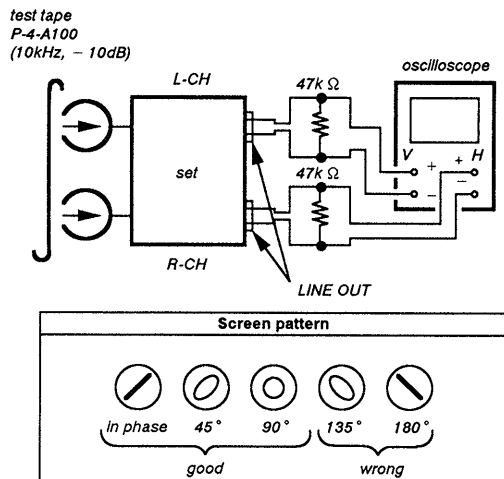

4. Change the reverse playback mode and repeat the steps 1 to 3.
5. After the adjustment, lock the adjustment screws with suitable locking compound.

Adjustment Location : – record/playback head –

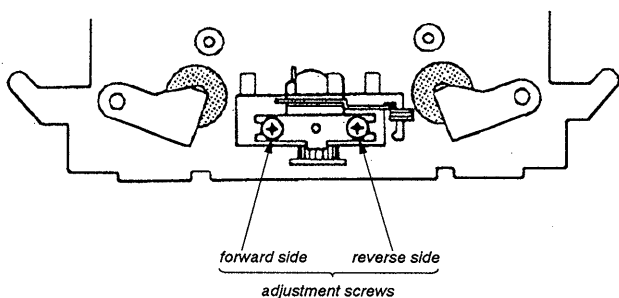

Tape Speed Adjustment DECK-A DECK-B

Procedure :

– Forward Playback Mode –

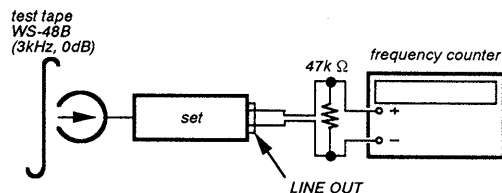

(High speed adjustment)

1. Set to test mode. (Refer to page 7)
2. Set to FWD playback mode.
3. Keep on pressing the HIGH SPEED DUBBING switch.
4. Adjust RV72 so that the frequency counter reading becomes $6,000 \pm 20\text{Hz}$.
5. Release test mode after adjustment is completed.

(Normal speed adjustment)

1. Set to FWD playback mode.
2. Adjust RV71 so that the frequency counter reading becomes $3,000 \pm 10\text{Hz}$.

(Pitch control adjustment) (TC-WE505/WE705S only)

1. Turn ON the PITCH CONTROL switch.
2. Set RV902 to mechanical center.
3. Set to FWD playback mode.
4. Adjust RV601 so that the frequency counter reading becomes $3,000 \pm 10\text{Hz}$.

Frequency difference between the beginning and the end of the tape should be within 3%.

Frequency difference between the deck A and deck B the beginning of the tape should be within 1.5%.

Adjustment Location : AUDIO board, MAIN board.

(See page 10)

Playback Level Adjustment DECK-A DECK-B

Procedure :

– Forward Playback Mode –

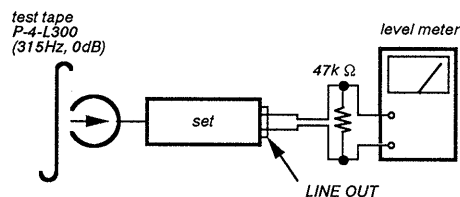

Adjust RV11(L-CH) and RV21(R-CH) so the level meter reading becomes the adjustment limits below.

Adjustment Value :

LINE OUT level : $-7.7 \pm 0.5\text{dB}$ (0.301 to 0.338V)

Level difference between channels : within 0.5dB

Confirm the LINE OUT level does not change in playback mode while changing the mode from playback to stop several times.

Adjustment Location : AUDIO board. (See page 10)

Bias Consumption Current Adjustment **DECK-B**

This adjustment should be performed when replacing the head assy or the bias oscillating transformer (T81, T91).

Procedure :

< > : R-CH

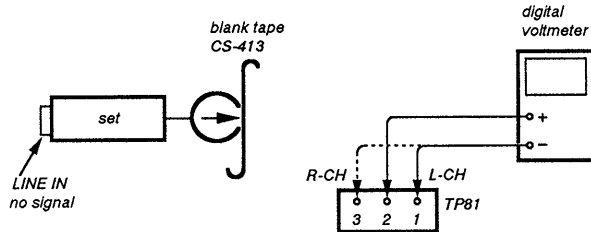

1. Connect the digital voltmeter to test point TP81.
2. Set RV81(RV91) to mechanical center.
3. Set to FWD record mode.
4. Adjust T81(T91) so that the digital voltmeter reading becomes minimum.

Adjustment Value : Maximum 220mV

Adjustment Location : AUDIO board. (See page 10)

Record Bias Adjustment **DECK-B**

Setting :

REC LEVEL control : standard record position (Refer to page 7.)

Procedure :

1. Record Mode

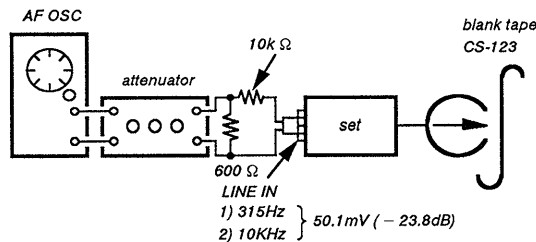

2. Playback Mode

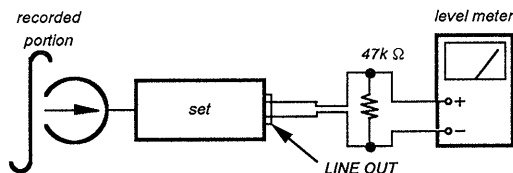

Confirm that the 10kHz playback output is $0 \pm 0.5\text{dB}$ relative to the 315Hz output. If necessary, adjust RV81 (L-CH), RV91(R-CH) and repeat the steps given above.

Adjustment Location : AUDIO board. (See page 10)

Record Level Adjustment **DECK-B**

Setting :

REC LEVEL control : standard record position (Refer to page 7.)

Procedure :

1. Record Mode

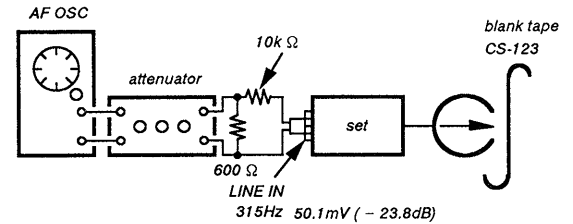

2. Playback Mode

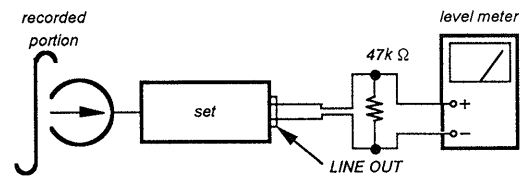

Confirm playback the tape recorded become adjustment level as follows.

If necessary, adjust RV101(L-CH), RV201(R-CH) and repeat the steps 1 and 2.

Adjustment Value :

LINE OUT level : $-23.8 \pm 0.5\text{dB}$ (47.2 to 53mV)

Adjustment Location : MAIN board.

(See page 10)

— Adjustment Parts Location Diagrams —

[MAIN BOARD]

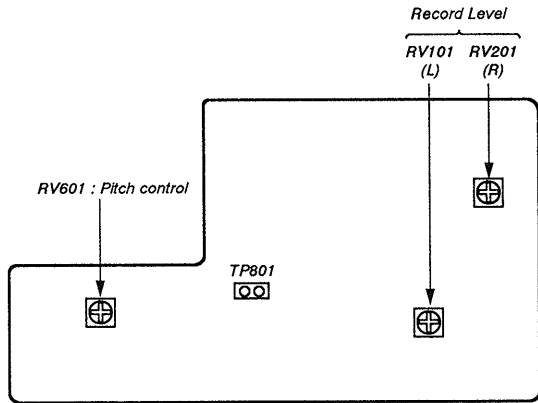

DECK-A :
[AUDIO BOARD]

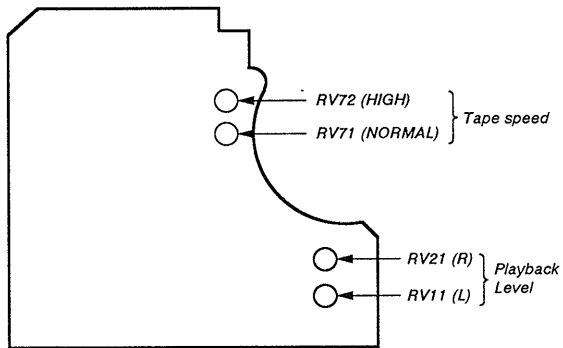

DECK-B :
[AUDIO BOARD]

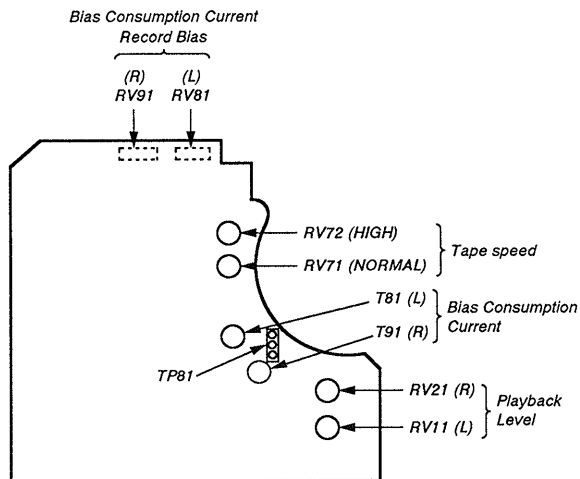

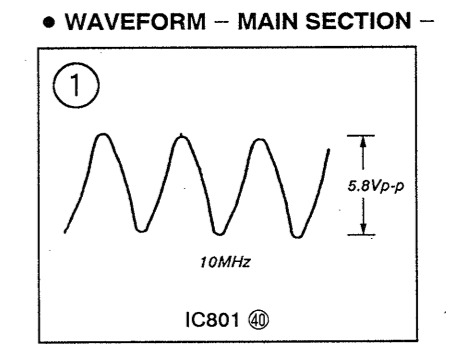
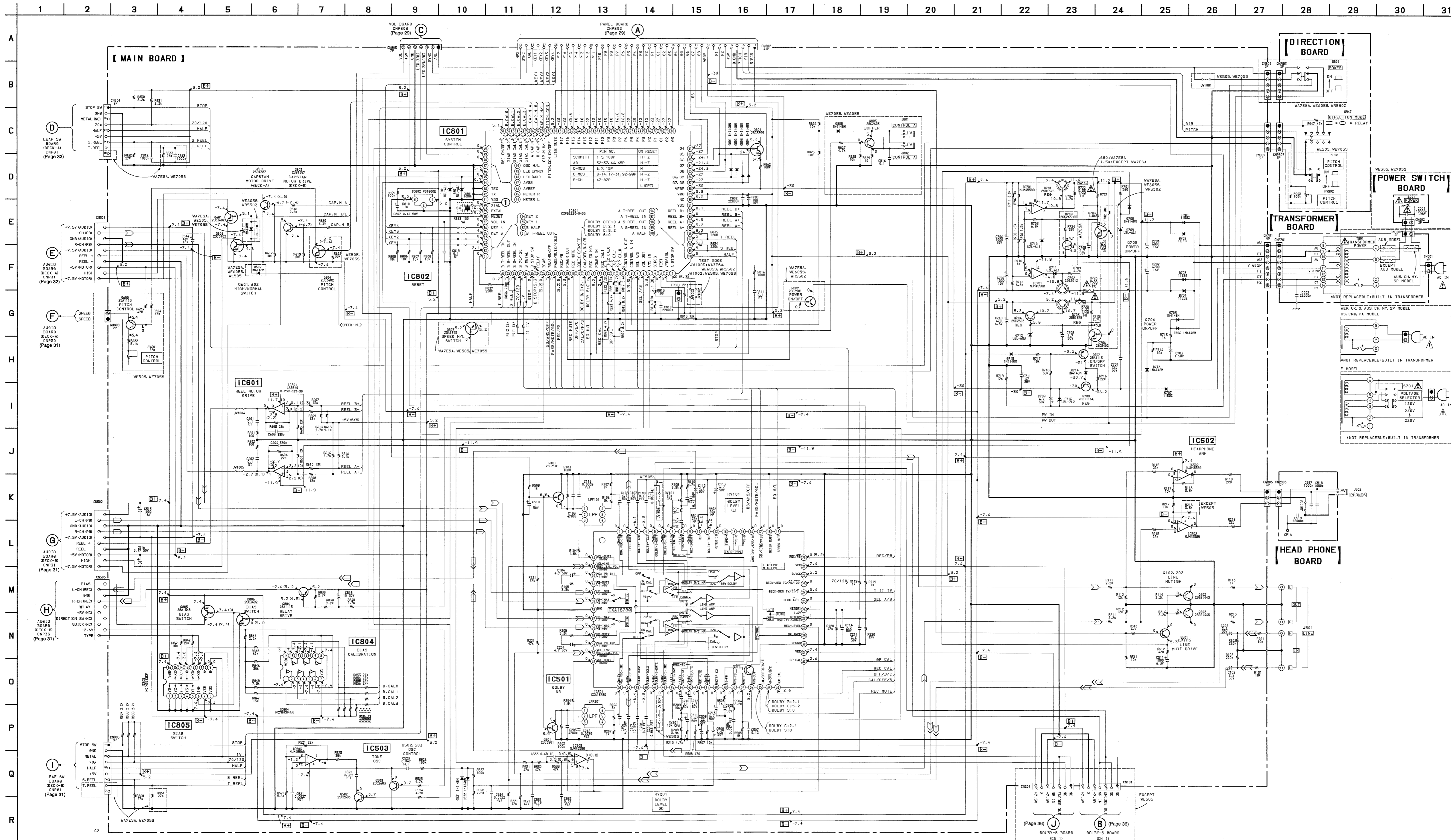

Note:

- All capacitors are in μF unless otherwise noted. pF : $\mu F \times 10^{-6}$ 50WV or less are not indicated except for electrolytics and tantalums.
- All resistors are in Ω and $\frac{1}{4}W$ or less unless otherwise specified.
- Δ : internal component.
- \sim : fusible resistor.

Note: The components identified by mark Δ or dotted line with mark Δ are critical for safety. Replace only with part number specified.

Note: Les composants identifiés par une marque Δ sont critiques pour la sécurité. Ne les remplacer que par une pièce portant le numéro spécifié.

Legend:

- \square B+ : B+ Line
- \square B- : B- Line
- \square : adjustment for repair.

Additional Notes:

- Voltage and waveforms are dc with respect to ground under no-signal conditions.
- no mark : STOP
- () : REC
- Ⓞ : Voltages are taken with a VOM (input impedance 10M Ω). Voltage variations may be noted due to normal production tolerances.
- Waveforms are taken with an oscilloscope. Voltage variations may be noted due to normal production tolerances.
- Circled numbers refer to waveforms.
- Signal path:
 - \Rightarrow PB (DECK A)
 - \Rightarrow PB (DECK B)
 - \Rightarrow REC (DECK B)

Abbreviation:

- CND : Canadian
- G : German
- AUS : Australian
- CH : Chinese
- SP : Singapore
- MY : Malaysia
- PA : Panama

5-4. SCHEMATIC DIAGRAM (PANEL SECTION)

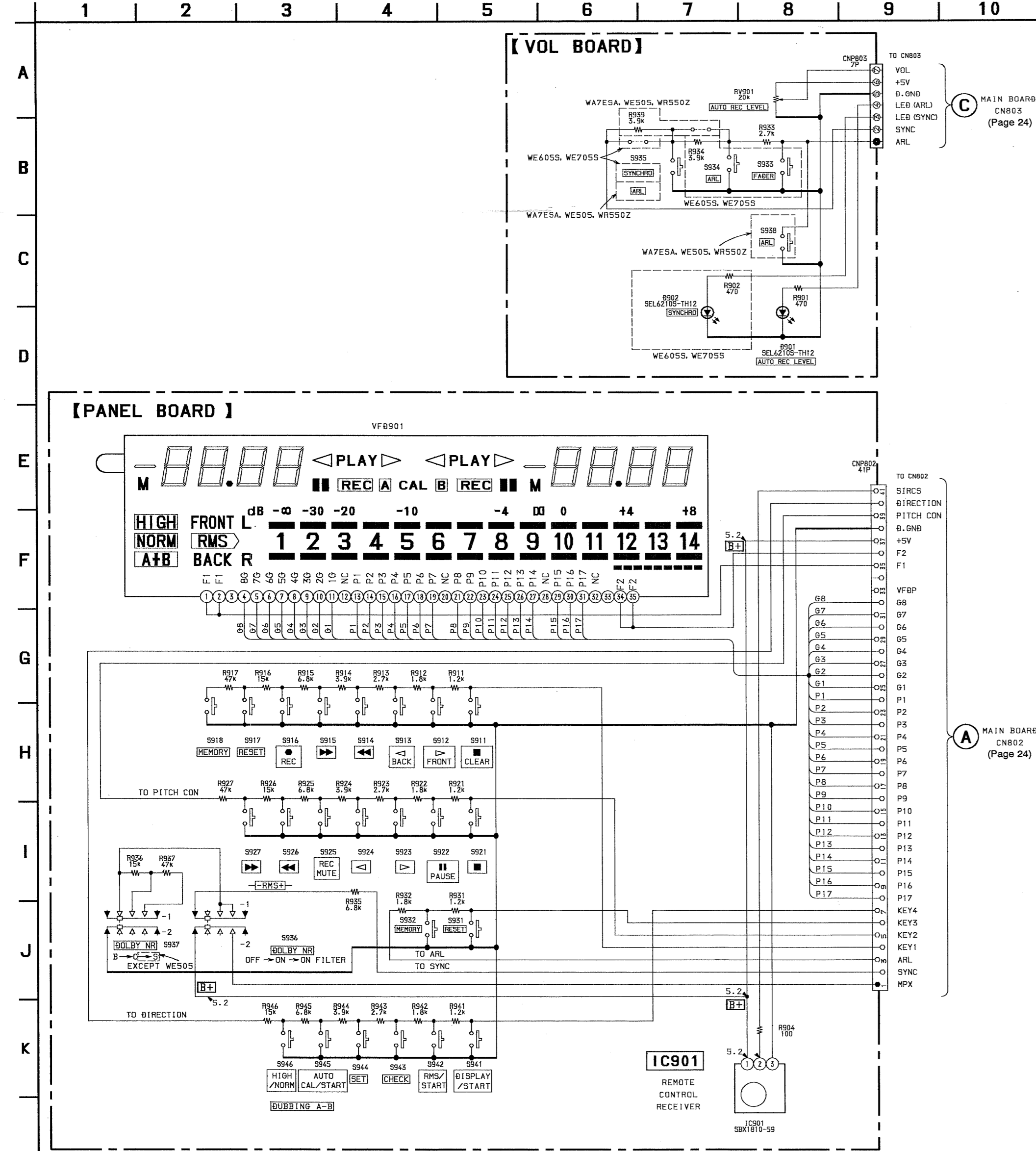

5-5. SCHEMATIC DIAGRAM (AUDIO SECTION)

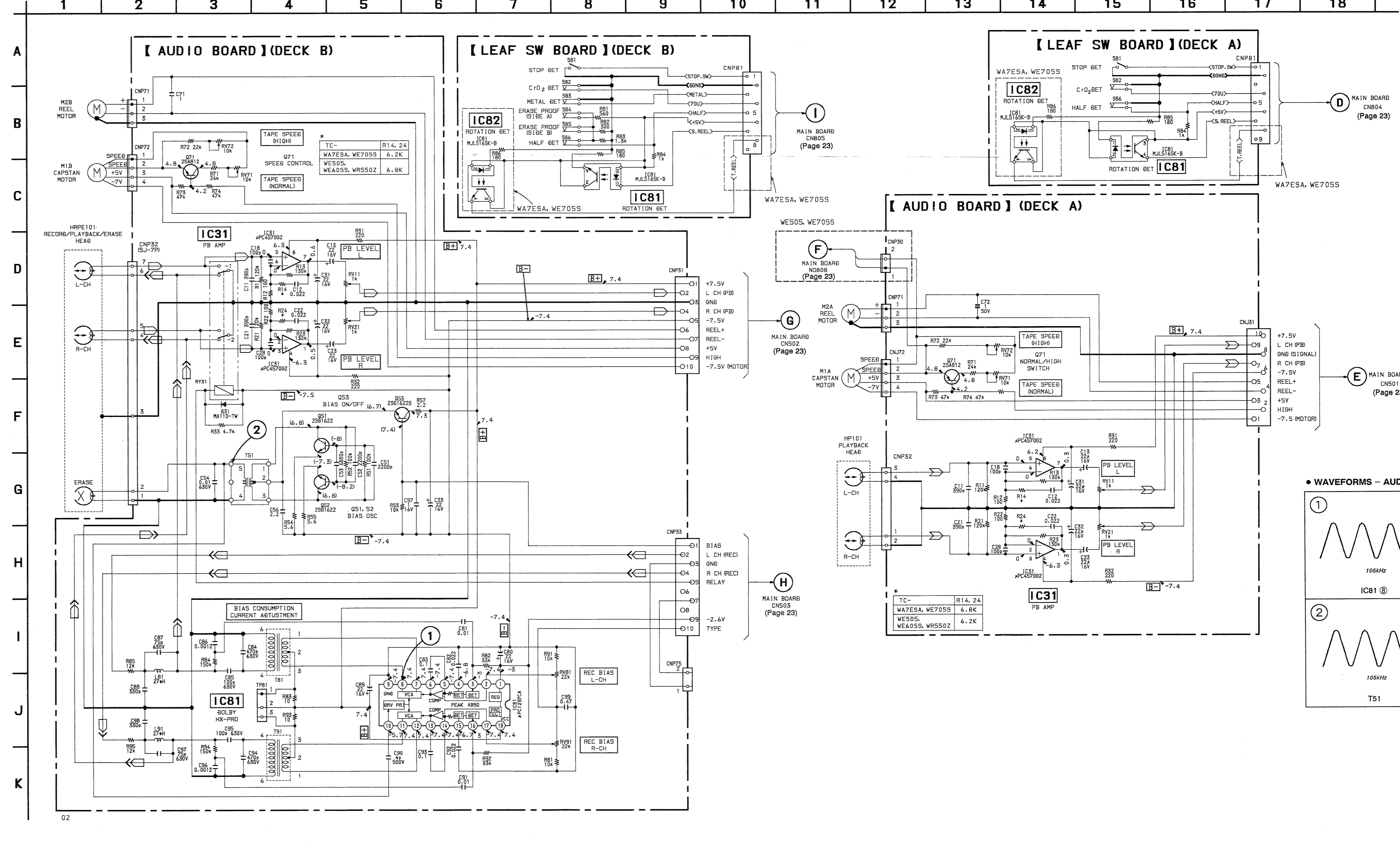

Note :

- All capacitors are in μF unless otherwise noted. pF: μF 50WV or less are not indicated except for electrolytics and tantalums.
- All resistors are in Ω and $\frac{1}{2}W$ or less unless otherwise specified.
- [B+] : B+ Line
- [B-] : B- Line
- [] : adjustment for repair.
- Voltage and waveforms are dc with respect to ground under no-signal conditions.
- no mark : STOP
- () : REC
- Voltages are taken with a VOM (Input impedance 10M Ω). Voltage variations may be noted due to normal production tolerances.
- Waveforms are taken with an oscilloscope. Voltage variations may be noted due to normal production tolerances.
- Circled numbers refer to waveforms.
- Signal path
- [] : PB (DECK A)
- [] : PB (DECK B)
- [] : REC (DECK B)

• WAVEFORMS - AUDIO SECTION -

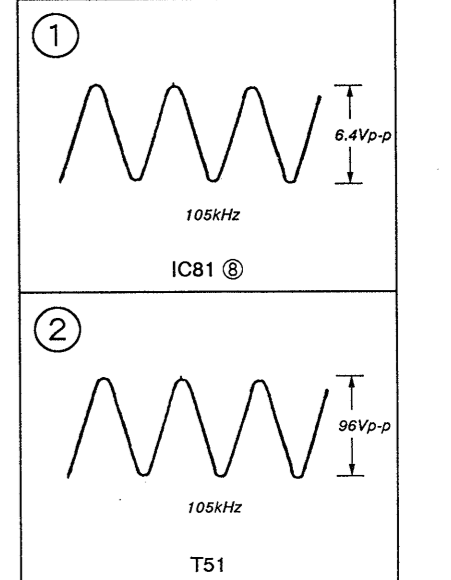

5-7. PRINTED WIRING BOARDS (DOLBY SECTION)
(EXCEPT WE505)

[DOLBY S BOARD]

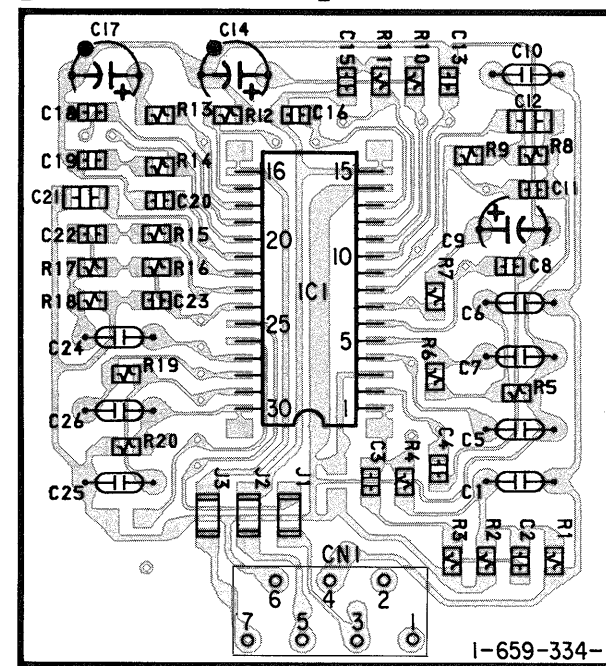

(Page 19) **G** **H** (Page 19)
MAIN BOARD
CN101, 201

Note:

- — : parts extracted from the component side.
- ▨ : Pattern on the side which is seen.

5-8. SCHEMATIC DIAGRAM (DOLBY SECTION)
(EXCEPT WE505)

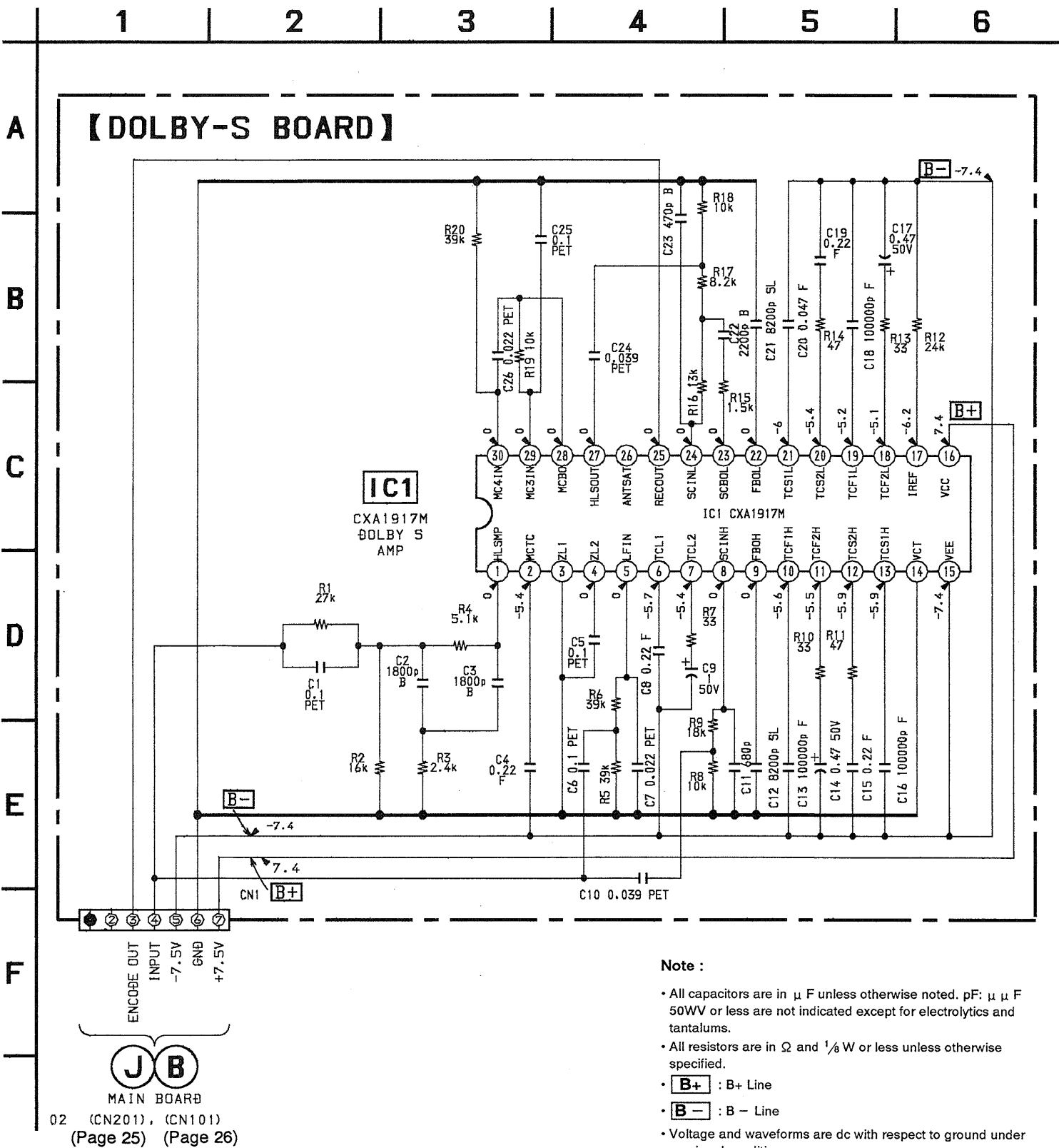

IC BLOCK DIAGRAM
IC1 CXA1917M-T6

