

# Technics

Stereo Integrated Amplifier

## SU-V4X

### OPERATING INSTRUCTIONS

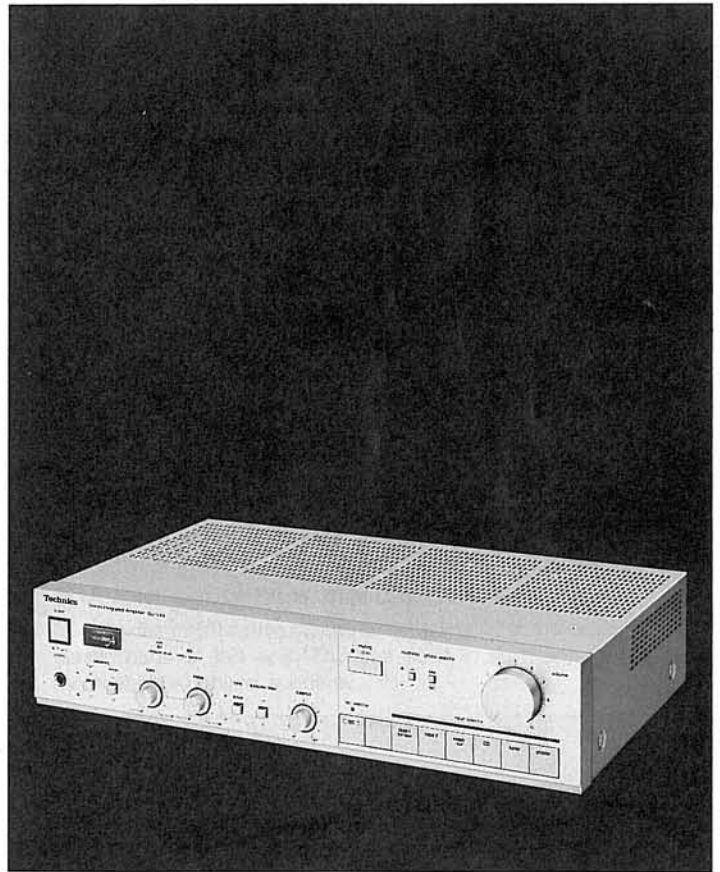

Also available in black.

**Notes:**

- Specifications differ according to the area code.
- The "EK" area code, for example, indicates United Kingdom specifications.
- The "EK" indication is shown on the packing case and serial number tag.

Before operating this unit, please read these instructions completely.

## Dear Stereo Fan

We want to thank you for selecting this product and to welcome you to the growing family of satisfied Technics product owners around the world. We feel certain you will get maximum enjoyment from

this new addition to your home. Please read these operating instructions carefully, and be sure to keep them handy for convenient reference.

### CONTENTS

• ACCESSORY .....	2
• BEFORE USING THIS UNIT .....	2
• FOR UNITED KINGDOM .....	2
• MAINTENANCE OF EXTERNAL SURFACES .....	2
• FOR SAFE USE OF THIS UNIT .....	3
• STEREO SYSTEM COMPONENTS AND THEIR CONNECTIONS .....	4
• FRONT PANEL CONTROLS AND THEIR FUNCTIONS .....	6
• OPERATION .....	8
• RECORDING .....	9
• TECHNICAL SPECIFICATIONS .....	10
• PROTECTION CIRCUITRY .....	10
• TROUBLESHOOTING GUIDE .....	11

### BEFORE USING THIS UNIT

Be sure to disconnect the mains cord before adjusting the voltage selector.

Use a minus (-) screwdriver to set the voltage selector (on the bottom panel) to the voltage setting for the area in which the unit will be used.

Note that this unit will be seriously damaged if this setting is not made correctly. (There is no voltage selector for some countries; the correct voltage is already set.)

### FOR UNITED KINGDOM

("EK" area code model only)

The "EK" indication is shown on the name plate.

#### Important

THE WIRES IN THIS MAINS LEAD ARE COLOURED IN ACCORDANCE WITH THE FOLLOWING CODE.

BLUE: NEUTRAL

BROWN: LIVE

As the colours of the wires in the mains lead of this unit may not correspond with the coloured markings identifying the terminals in your plug, proceed as follows. The wire which is coloured BLUE must be connected to the terminal which is marked with the letter N or coloured BLACK.

The wire which is coloured BROWN must be connected to the terminal which is marked with the letter L or coloured RED.

### MAINTENANCE OF EXTERNAL SURFACES

To clean, use a soft dry cloth.

If the surfaces are extremely dirty, use a soft cloth, dipped into a soap and water solution or a weak detergent solution.

Wring the cloth well before wiping the unit.

Wipe once again with a soft dry cloth.

Never use alcohol, paint thinner, benzene, nor a chemically treated cloth to clean this unit.

Such chemicals may damage the finish of your unit.

### ACCESSORY

- AC power supply cord (Except for Australia) ..... 1

# FOR SAFE USE OF THIS UNIT

## ■ Use a standard electrical AC wall outlet

1. **Use from an AC power source of high voltage, such as for air conditioners, is very dangerous.**

Be extremely careful not to make a connection to the electrical outlet for a large air conditioner or central-heating unit which uses high voltage, because there is the possibility of fire.

2. **A DC power source cannot be used.**

Be sure to check the power source carefully, especially on a ship or other place where DC is used.



## ■ Connection and removal of the power cord plug

1. **Wet hands are dangerous.**

A dangerous electric shock may result if the plug is touched by wet hands.

2. **Don't pull the power cord.**

Always grasp the plug; never pull the cord itself.

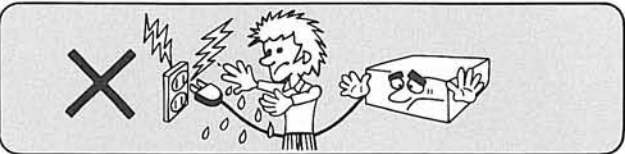

## ■ Never attempt to repair or reconstruct this unit

A serious electric shock might occur if this unit is repaired, disassembled or reconstructed by unauthorized persons, or if the internal parts are accidentally touched.



## ■ For families with children

Never permit children to put anything, especially metal, inside this unit. A serious electric shock or malfunction could occur if articles such as coins, needles, screwdrivers, etc. are inserted through the ventilation holes, etc. of this unit.



## ■ Turn off after use

If the unit is left for a long time with the power on, this will not only shorten its useful operation life, but may also cause other unexpected trouble.



## ■ If water is spilled on the unit

Be extremely careful if water is spilled on the unit, because a fire or serious electric shock might occur. Immediately disconnect the power cord plug, and consult with your dealer.

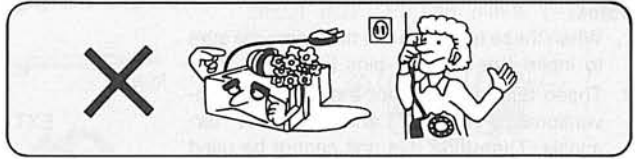

## ■ Place the unit where it will be well ventilated, and away from direct sunlight

Place this unit at least 10 cm (4") away from wall surfaces, etc., and away from direct sunlight. Be careful that curtains and similar materials do not obstruct the ventilation holes.

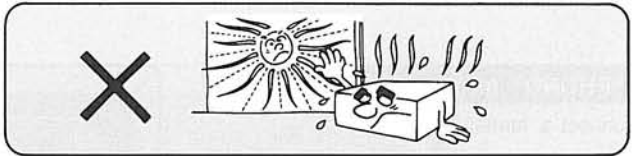

## ■ Keep the unit away from heaters, etc.

Heat can damage the external surfaces as well as internal circuits and components.

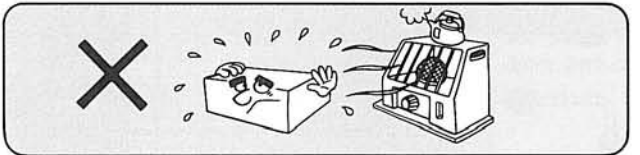

## ■ Avoid spray-type insecticides

Insecticides might cause cracks or "cloudiness" in the cabinet and plastic parts of this unit. The gas used in such sprays might, moreover, be ignited suddenly.



## ■ Never use alcohol or paint thinner

These and similar chemicals should never be used, because they may damage the finish.



## ■ If trouble occurs

If, during operation, the sound is interrupted or indicators no longer illuminate, or if abnormal odor or smoke is detected, immediately disconnect the power cord plug, and contact your dealer or an Authorized Service Center.

# STEREO SYSTEM COMPONENTS AND THEIR CONNECTIONS

## "EXT OUT EXT IN" terminals

A graphic equalizer or a microphone-mixing amplifier can be connected these terminals.

**Notes:**

1. When these terminals are not in use, be sure to insert the shorting pins (included).
2. These terminals are not the same as conventional "PRE OUT" and "MAIN IN" terminals. Therefore, this unit cannot be used in a multi-amplifier system or a three-dimensional system.

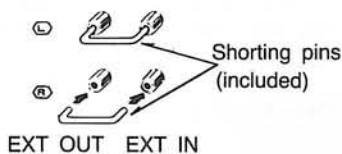

## "TAPE 1/DA TAPE" terminals

In addition to a tape deck, the audio from a digital audio processor or video cassette recorder (stereo type) can be connected here. If such equipment is connected, connect the tape deck to the "TAPE 2" terminals.

## "PHONO" terminals

Connect a turntable.

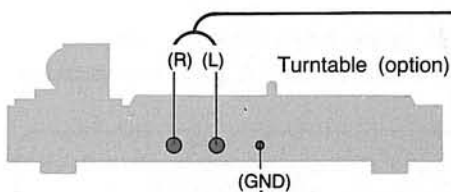

## "TUNER" terminals

Connect a tuner.

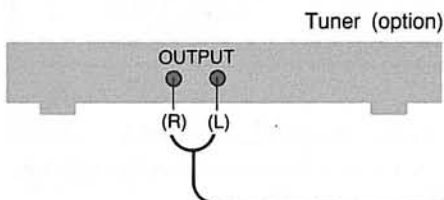

## "CD" terminals

Connect a compact disc player.

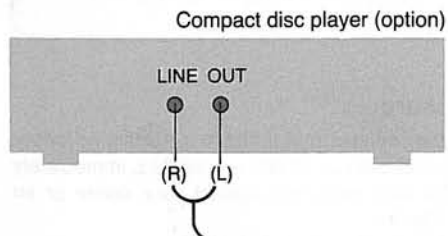

## "TAPE 2" terminals

Connection to second tape deck.

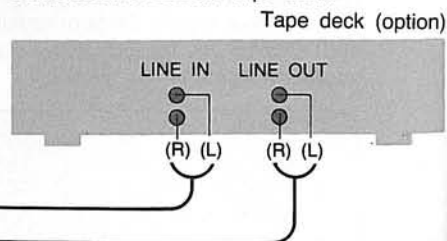

## "VIDEO/AUX" terminals

Connect a TV etc. These terminals are for audio playback only.

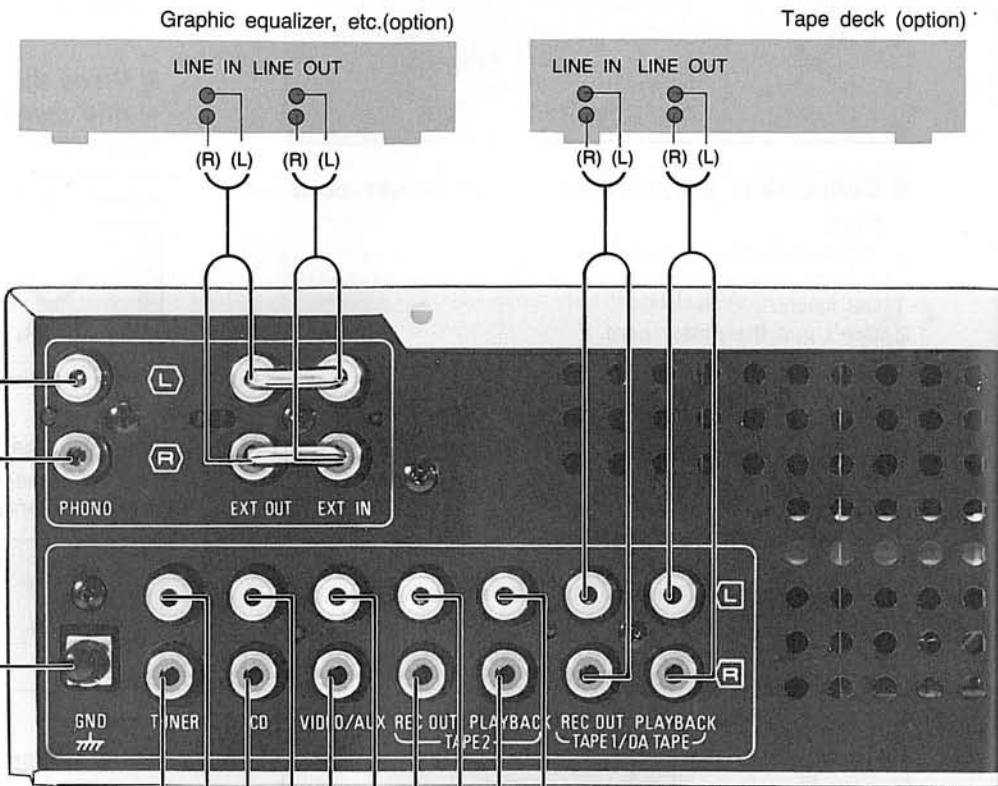
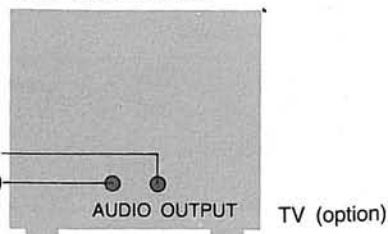



**"SPEAKERS" terminals**

■ **Load impedance:**

MAIN and REMOTE 8~16Ω  
 MAIN or REMOTE 4~16Ω

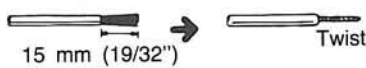
■ **Connection of speaker wires**

1. Strip off the outer covering, and twist the center conductor.  

2. Turn completely to the left.  

3. Insert wire and turn completely to the right. Pull wire to be sure it won't come out.  

**Note:**

To prevent damage to circuitry, never short-circuit plus (+) and minus (-) speaker terminals.



■ **"REMOTE" terminals**

Connection to second pair of speakers.

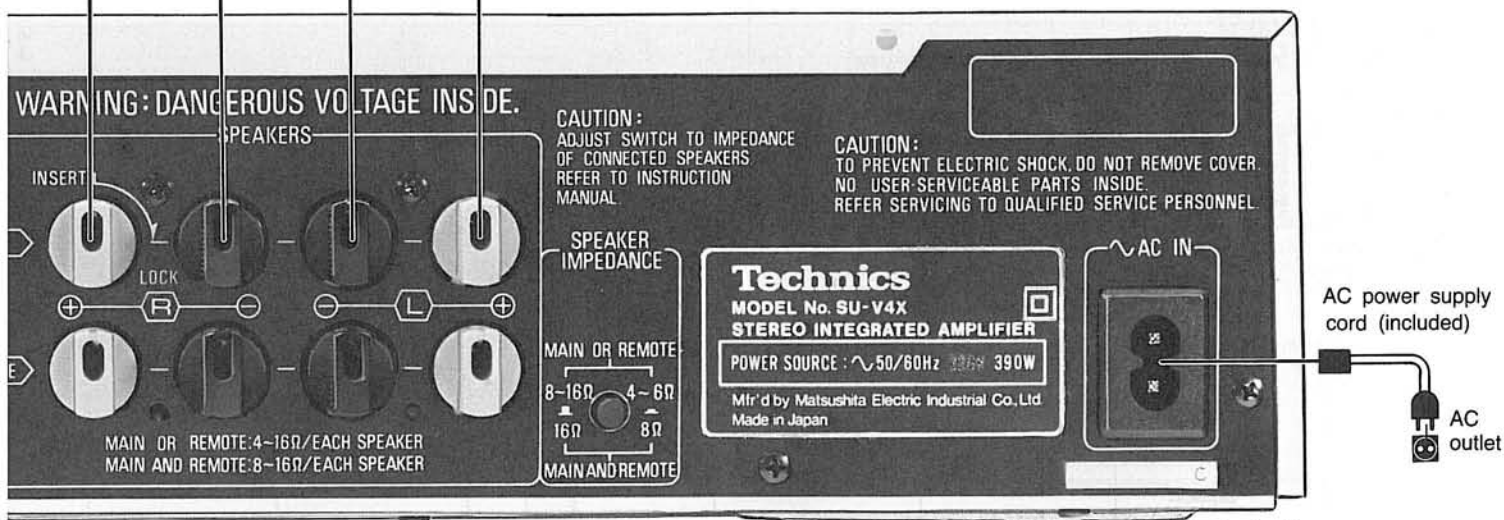
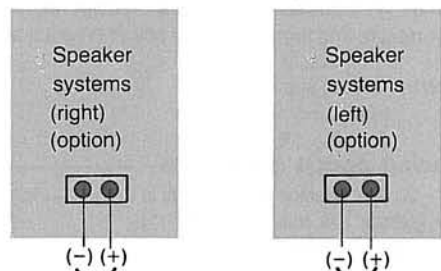

**For Australia**  
 AC power supply cord is not connected separately; it is connected directly to the rear panel.

**Speaker impedance selector (SPEAKER IMPEDANCE)**

Set to the position corresponding to the impedance of the speaker systems being used.

If this setting is not correctly made, the result may be a deterioration of performance.

■ **If either the main or the remote speaker systems are used:**

4~6Ω (II-III):

For speaker impedance of 4~6Ω.

8~16Ω (I-III):

For speaker impedance of 8~16Ω.

■ **If both main and remote speaker systems are used:**

8Ω (II-III):

For speaker impedance of 8Ω or more and less than 16Ω.

16Ω (I-III):

For speaker impedance of 16Ω.

Note that, if 2 pairs of speaker systems are used at the same time, determine the composite impedance as described below.

$$R = \frac{R_1 \times R_2}{R_1 + R_2}$$

Where:

R = total impedance

R<sub>1</sub> = impedance of speaker systems connected to "MAIN" terminals

R<sub>2</sub> = impedance of speaker systems connected to "REMOTE" terminals

**Note:**

Be sure to make this setting before switching the power "on".

# FRONT PANEL CONTROLS AND THEIR FUNCTIONS

## Power switch (power)

Before turning the power on, make sure the volume control of this unit is set to the low ("0→1") position.

## Computer-drive automatic indicator (auto)

This indicator will illuminate when the circuitry is in the stabilized condition.

## Operation indicator (safety operation)

When the power is switched on, this indicator flashes on and off for about 5 seconds, and then illuminates steadily when the unit is in the operation condition. If an abnormal condition in the circuitry is detected, such as DC voltage appearing in the output, or a short-circuit of the positive (+) and negative (-) cords from the speaker terminals, the protection circuit functions and this indicator flashes rapidly. If this occurs, switch the power off, find the cause of the trouble and correct it, and then switch the power on once again.

## Audio muting switch (muting)

Set to the "-20 dB" position when a disc is being changed or to temporarily reduce the volume level. (The indicator will be illuminated).

In addition, the volume level can be adjusted more precisely if this switch is set to the "-20 dB" position for listening at a low volume level.

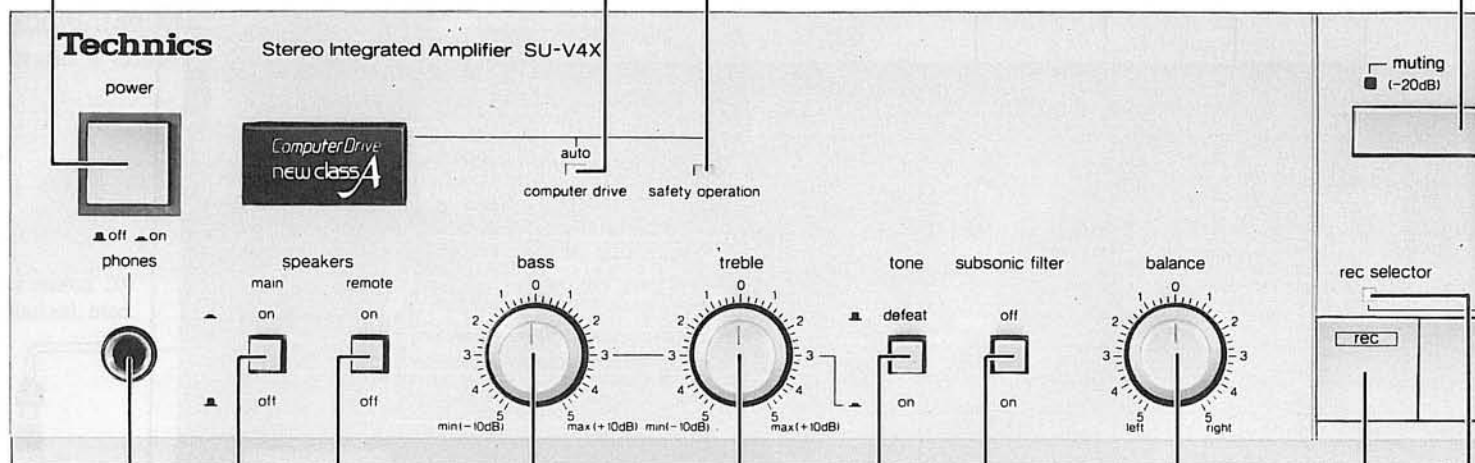

## Tone controls (bass/treble)

The bass control is for the low-frequency sound range, and the treble control is for the high-frequency sound range.

## Balance control (balance)

This control is used to adjust left/right volume balance.

## Speaker selectors (speakers)

These selectors are used to turn the speaker systems on and off.

### main:

Sound can be heard from the speakers connected to the "MAIN" terminals.

### remote:

Sound can be heard from the speakers connected to the "REMOTE" terminals.

### Note:

Before use, set the speaker impedance selector (on the rear panel) to the correct impedance corresponding to the impedance of the speaker systems being used. (Refer to page 5.)

## Subsonic filter switch (subsonic filter)

Set to "on" position to eliminate noise in the low-frequency range (caused by warped discs or motor "rumble").

## Tone switch (tone)

This switch is used to turn the tone control circuit (bass, treble) on or off.

### defeat (⏏):

Set to this position to turn the bass/treble tone control circuit off. Regardless of the positions of the bass/treble tone controls the characteristics will remain flat.

### on (⏏):

Set to this position for adjustment of the tone quality with the tone controls.

## Headphones jack (phones)

● **Loudness switch (loudness)**

Set to the "on" position when listening to music at a low volume. Auditory perception of sound in the low frequency range falls off at low volume, but when the switch is in this position, this deficiency is compensated for, so that the full impact of the musical performance can be enjoyed.

● **Phono cartridge selector (phono selector)**

This selector should be set to the position which corresponds to the type of cartridge used on the turntable.

**MM (— — |):**

Set to this position when using a moving-magnet type cartridge or high-output moving-coil cartridge (1 mV or more).

**MC (| — —):**

Set to this position when using a moving-coil type cartridge.

● **Volume control (volume)**

This control is used to adjust the volume level.

Be absolutely sure to set this control to the low position ("0 → 1") before turning the power on. After the power is turned on, please wait several seconds before increasing the volume level.

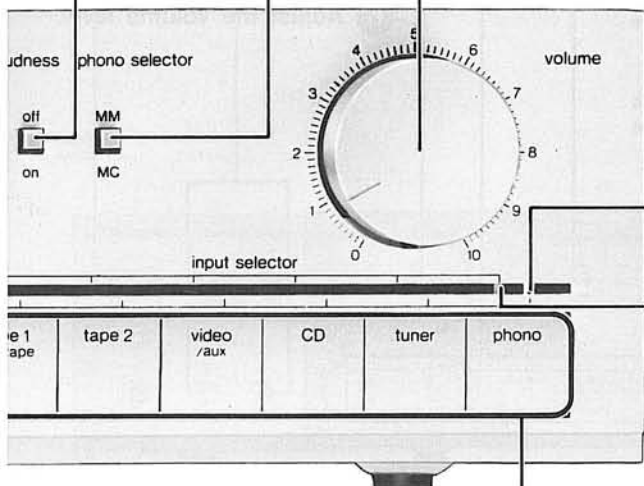

● **Recording output signal indicator**

This indicator indicates the sound source which can be recorded.

● **Input signal indicator**

This indicator indicates the sound source of the sound being heard from the speakers.

● **Recording mode indicator (rec selector)**

● **Recording mode switch (rec)**

This button can be used to select another program source to listen to while recording from one tape to another tape or while recording from some other program source.

When this button is pressed, the recording mode indicator flashes, and, when one of the selectors is pressed, this indicator illuminates.

If the indicator flashes, the flashing can be stopped by pressing this switch once again.

**When the recording mode indicator is not illuminated:**

If one of the selectors is pressed, the sound source to be listened to and the recording sound source will both be switched at the same time.

Note, however, that only the sound source to be listened to will be switched, and the tape can be monitored during recording, if the "tape 1/DA tape" or "tape 2" selectors are pressed.

**When the recording mode indicator is flashing:**

If one of the selectors is pressed, only the recording sound source will be switched.

**When the recording mode indicator is illuminated:**

If one of the selectors is pressed, only the sound source to be listened to will be switched.

● **Selectors (input selector/rec selector)**

Press to select the sound source to be listened to and/or the sound source to be recorded.

Note that the function of these selectors changes depending upon the setting of the recording mode switch. (Refer to "Recording mode switch".)

**phono:**

Press this button to listen to and/or record phono discs.

**tuner:**

Press this button to listen to and/or record radio broadcasts.

**CD:**

Press this button to listen to and/or record a compact disc.

**video/aux:**

Press this button to listen to and/or record sound from a video cassette recorder or other equipment connected to the "VIDEO/AUX" terminals on the rear panel.

**tape 2:**

Press this button to playback, monitor, or dub the sound from tape deck 2.

**tape 1/DA tape:**

Press this button to playback, monitor, or dub the sound of a digital audio processor or other equipment connected to the "TAPE 1/DA TAPE" terminals on the rear panel.

## OPERATION

**Note:** After listening is finished, power switches of all equipment should be turned "off".

2 Power: "on" (I → II)

3 Select speaker systems to be used.

4 Select the sound source.

**phono:**

Press this button to listen to phono discs.

"MM" (II → III): for moving-magnet cartridge.

"MC" (III → IV): for moving-coil cartridge.

**tuner:**

Press this button to listen to radio broadcasts.

**CD:**

Press this button to listen to a compact disc.

**video/aux:**

Press this button to listen to sound from a video cassette recorder or other equipment connected to the "VIDEO/AUX" terminals on the rear panel.

**tape 2:**

Press this button to playback or monitor the sound from tape deck 2.

**tape 1/DA tape:**

Press this button to playback or monitor the sound of a digital audio processor or other equipment connected to the "TAPE 1/DA TAPE" terminals on the rear panel.

1 "0 → 1"

5 Follow the operating instructions for the equipment connected.

6 Adjust the volume level.

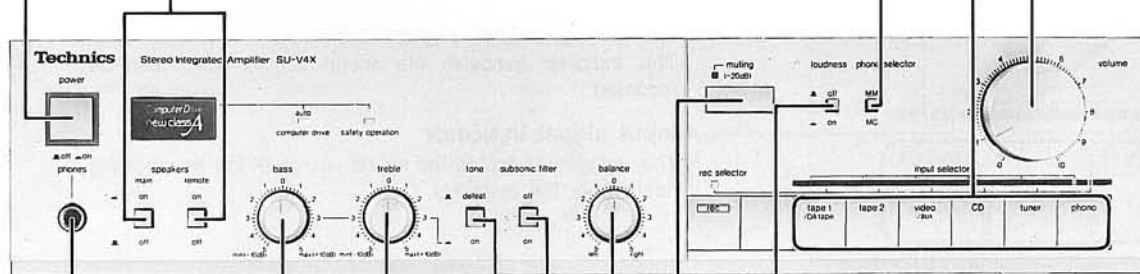

Headphones  
(option)

If sound from speakers is not wanted, set the speaker selectors to the off position.

**Note:** Set volume control to minimum ("0") position before connecting headphones.

Adjust tone quality as desired. Low-range sound is adjusted with bass control ("bass"), and high-range sound with treble control ("treble").

Adjust to desired tone quality. If set to "defeat" position, tone controls have no effect, and frequency response becomes flat.

■ Steps required for all operations

(Follow these steps, as necessary, for all operations after adjusting of volume level.)

● Set to "on" (I → II) position when listening at a low volume level.

● Set to the "-20 dB" position to temporarily reduce the volume level. (The indicator will be illuminated).

● Adjust left/right volume balance.

While listening to an AM broadcast or a monaural FM broadcast, balance the sound so that it seems to be heard from the center, between the speakers.

● Set to the "on" position to eliminate ultra-low-frequency noise (to eliminate turntable motor "rumble", etc.).

# RECORDING

1 Power: "on" (I-III)

2 Select speaker systems to be used.

3 Press.  
(The recording mode indicator will flash.)

4 Select the sound source for recording.  
(The recording mode indicator and recording output signal indicator will illuminate.)

● Press this button in order to record from the tape deck connected to the "TAPE 1/DA TAPE" terminals (on the rear panel) to the tape deck connected to the "TAPE 2" terminals.

● Press this button in order to record from the tape deck connected to the "TAPE 2" terminals (on the rear panel) to the tape deck connected to the "TAPE 1/DA TAPE" terminals.

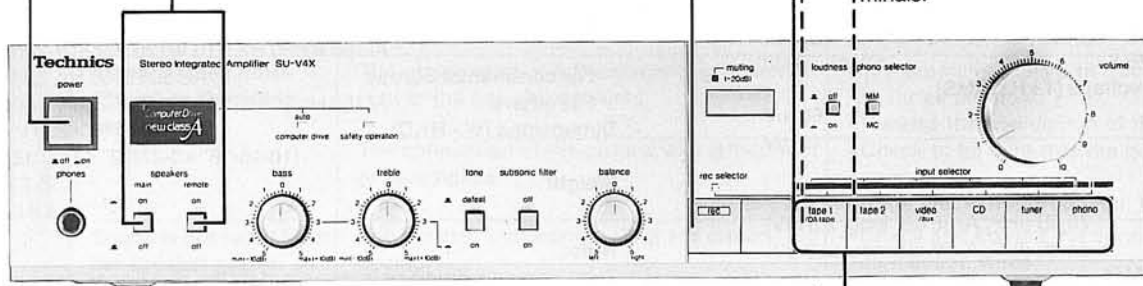

5 Operation of tape deck  
By using the controls on the tape deck, adjust the recording level. Then begin recording.

6 Select the desired sound source to be heard.  
(The input signal indicator will illuminate.)

## Note:

### 1. Recording mode switch

When the recording mode switch is pressed two times, the illumination of the recording mode indicator will stop. Note that the recording sound source will be changed, interrupting the recording, if this is done while a recording is being made. (Refer to page 7.)

### 2. Timer recordings

Note that the recording might not be made if a timer recording is made while the recording mode indicator is flashing. Be sure to check to be sure that the recording mode indicator is illuminated steadily (not flashing).

● If the sound source which is being recorded from is selected:  
The sound can be heard immediately before it is recorded.

● If the tape deck making the recording is selected:  
The sound can be heard immediately after it is recorded.

● If some other sound source is selected:  
The sound of the selected source can be heard. (This will not affect the recording which is being made.)

### To record a different sound source

Follow steps (3) through (6).

## TECHNICAL SPECIFICATIONS

### (DIN 45 500)

#### ■ AMPLIFIER SECTION

<b>1 kHz continuous power output</b> both channels driven	2×70 W (4Ω) 2×70 W (8Ω)
<b>20 Hz~20 kHz continuous power output</b> both channels driven	2×65 W (4Ω) 2×65 W (8Ω)
<b>Total harmonic distortion</b> rated power at 20 Hz~20 kHz	0.03% (4Ω) 0.004% (8Ω)
rated power at 1 kHz	0.007% (4Ω) 0.003% (8Ω)
half power at 20 Hz~20 kHz	0.003% (8Ω)
half power at 1 kHz	0.001% (8Ω)
<b>Intermodulation distortion</b> rated power at 250 Hz: 8 kHz=4:1, 8Ω	0.03%
rated power at 60 Hz: 7 kHz=4:1, SMPTE, 8Ω	0.004%
<b>Power bandwidth</b> both channels driven, -3 dB	5 Hz~50 kHz (4Ω, 0.03%) 5 Hz~60 kHz (8Ω, 0.02%)
<b>Residual hum and noise</b>	0.9 mV
<b>Damping factor</b>	30 (4Ω), 60 (8Ω)
<b>Input sensitivity and impedance</b>	
PHONO MM	2.5 mV/47 kΩ
MC	170 μV/220Ω
TUNER, CD, VIDEO/AUX	150 mV/22 kΩ
TAPE 1/DA TAPE, TAPE 2	150 mV/22 kΩ
<b>PHONO maximum input voltage (1 kHz, RMS)</b>	
MM	160 mV
MC	12 mV
<b>S/N</b> rated power (4Ω)	
PHONO MM	76 dB (IHF, A: 86 dB, input 2.5 mV)
MC	64 dB (IHF, A: 68 dB, input 250 μV)
TUNER, CD, VIDEO/AUX, TAPE 1/DA TAPE, TAPE 2	91 dB (IHF, A: 102 dB)

#### Frequency response

PHONO RIAA standard curve  
±0.8 dB (30 Hz~15 kHz)

#### TUNER, CD, VIDEO/AUX, TAPE 1/DA TAPE, TAPE 2

5 Hz~120 kHz (-3 dB)  
+0, -0.2 dB (20 Hz~20 kHz)

#### Tone controls

BASS 50 Hz, +10 dB~-10 dB  
TREBLE 20 kHz, +10 dB~-10 dB

#### Muting

-20 dB

#### Subsonic filter

30 Hz, -6 dB/oct.

#### Loudness control (volume at -30 dB)

50 Hz, +9 dB

#### Output voltage

150 mV

#### Channel balance, VIDEO/AUX 250 Hz~6,300 Hz

±1 dB

#### Channel separation, VIDEO/AUX 1 kHz

60 dB

#### Headphones output level and impedance

540 mV/330Ω

#### Load impedance

##### MAIN or REMOTE

4Ω~16Ω

##### MAIN and REMOTE

8Ω~16Ω

#### ■ GENERAL

#### Power consumption

390 W

#### Power supply

##### For United Kingdom

AC 50 Hz/60 Hz, 110 V/120 V/220 V/240 V

##### For continental Europe

AC 50 Hz/60 Hz, 220 V

##### For others

AC 50 Hz/60 Hz, 110 V/120 V/220 V/240 V

#### Dimensions (W×H×D)

430×97×290 mm

(16-15/16"×3-27/32"×11-7/16")

#### Weight

6.7 kg

(14.8 lb.)

#### Note:

Total harmonic distortion is measured by the digital spectrum analyzer (H.P. 3045 system).

Specifications subject to change without notice.

## PROTECTION CIRCUITRY

The protection circuitry may have operated if either of the following conditions is noticed:

- No sound is heard when the power is turned on.
- Sound stops during a performance.

The function of this circuitry is to prevent circuitry damage if, for example, the positive and negative speaker connection wires are "shorted", or if speaker systems with an impedance less than the indicated rated impedance of this unit is used.

If this occurs, follow the procedure outlined below:

1. Turn off the power.
2. Determine the cause of the problem and correct it.
3. Turn on the power once again.

#### Note:

When the protection circuitry functions, the unit will not operate unless the power is first turned off and then on again.

# TROUBLESHOOTING GUIDE

Before requesting service for this unit, check this table to determine if the problem can be solved as described below. If the problem still persists after making these checks, or if there are symptoms of malfunction not described in this table, it is recom-

mended that you consult the store where this unit was purchased or your local Service Center (see list included) for further information and assistance.

	Problem	Probable cause(s)	Suggested remedy
Problems noted at all times	<b>No sound is heard when the power is turned on.</b>	The power cord plug is not completely inserted.	• Confirm that the power cord plug is connected completely.
		The power supply fuse has failed.	• Request the store where this unit was purchased, or a Service Center, to replace the fuse.
		Connections are incomplete or incorrect to the speaker systems, etc.	• Check to be sure that all connection wires are correctly connected.
		The setting of the selectors has not been completely or correctly made.	• Check to be sure that the selectors are set to the correct position.
		The speaker selectors are incorrectly set to the "off" position.	• Set to the "on" position.
	<b>When listening to stereo sound, the sound of the various musical instruments is not heard from its correct position.</b>	The positive (+) and negative (-) connections of the speaker connection wires are reversed.	• Reconnect the speaker connection wires so that the positive and negative connections are correct.
	<b>When listening to stereo sound, the left and right sounds are reversed.</b>	The left and right connections of the speaker connection wires are reversed.	• Check the speaker connection wires and connect them correctly if necessary.
		The left and right connections of the connection wires connected to other equipment are reversed.	• Check the connection wires to other equipment and connect them correctly if necessary.
	<b>A low-pitched noise ("hum" or "buzz") is heard.</b>	The power cord or a fluorescent light, etc., is near the connection wires.	• Try separating this unit from the electric appliance as far as possible. • Reverse the connection of the power cord plug.
		The connection of the ground wire is incorrect or incomplete.	• Check to be sure that the grounding connection is correct. • If the unit is not grounded, try doing so.
<b>Sound is not heard from the speaker system on one side.</b>	The speaker connection wires are disconnected.	• Check and correct the connections of the speaker connection wires.	
	The balance control is not set to the center position.	• Set the mark on the balance control to the center position.	
<b>The volume level for a radio broadcast is different from that for disc play.</b>	The strength of the broadcast signal is not the same as the output from the turntable.	• Adjust the volume level by using the volume control.	
<b>While listening, sound is suddenly no longer heard. (Indication lamps of other equipment are still illuminated.)</b>	The protection circuitry of the amplifier has functioned.	• Check the connections to other equipment (especially the speaker connection terminals, etc.), and, if still no sound is heard, request service from the store where the unit was purchased or from your local Service Center.	
During disc play	<b>The sound lacks clarity and volume.</b>	The cartridge selector is incorrectly set to the "MM" position when a moving-coil type cartridge is being used.	• Set the cartridge selector to the "MC" position.
	<b>The high-frequency range cannot be clearly heard.</b>	The cartridge selector is incorrectly set to the "MC" position when a moving-magnet type cartridge is being used.	• Set the cartridge selector to the "MM" position.