

## First Watt model F5

### Operation and Service Manual

So far, First Watt has made a few different amplifiers: Very different amplifiers.

Quite a few people have asked me for a regular sort of amplifier, you know the kind you plug like any other, with some voltage gain and a real damping factor.

Amplifiers that have low distortion and noise, and will drive a 4 ohm load.

The last time people asked for that they got the Aleph J, which satisfied most of those requirements. Single-ended Class A, the Aleph J is an easy-going design which is happy driving 8 ohm loads with a warm, relaxed presentation.

By way of contrast, I present the F5 (taa-daa!), a push-pull Class A amplifier, utilizing JFETs and MOSFETs in a very simple two stage complementary circuit – a little bit like a complementary version of the Aleph J. But like all the other First Watt amps so far – this one is different.

In many ways, it's an ordinary topology - the basic circuit is found in numerous preamp circuits and the odd power amplifier (Check out the Profet amp from Selectronics). But the F5 is the product of numerous decisions that set it apart.

It has very wide bandwidth, DC to > 500 KHz.

No capacitors anywhere in the circuit. (except in the power supply, of course!)

It has a high input impedance – 100 Kohms, and a high damping factor (~60)

The distortion is very low, between .001% and .005% at 1 watt.

It's very quiet, about 60 microvolts or so.

It will drive a 2 ohm load without burping, and 1 ohm without misbehaving.

Did I mention that it sounds terrific?

So enjoy. In addition to the normal owner's manual information, I have appended the original DIY F5 article which appeared in AudioXpress.

Nelson Pass 5/24/08

## Setup

The initial setup of the amplifier is very straight-forward. Place the amplifier in a well-ventilated location, as it draws about 180 watts during operation and requires as much opportunity to cool itself as possible. You should be able to put your hands on the heat sink during operation. If you can't do this for 5 seconds or so, they need more ventilation.

On the front panel there are two blue LED lights, one for each channel, indicating power to the channel. On the rear panel you will find a pair of RCA inputs, speaker outputs, a fuse holder, an AC power receptacle, and on/off switch.

The label will indicate a serial number and also what AC line voltage the amplifier is set for. If the voltage is 120 VAC, then the fuse value will be a 3AG slow blow fuse rated at 2.5 amps. If the voltage is 240 VAC, then the fuse will be rated at 1.25 amps. Do not substitute a larger value fuse. Contact First Watt if you have any questions.

I'm assuming that you know how to attach the speaker cables to the 5 way output connectors provided. Please make all the connections with the amplifier power switch in the OFF position.

For two channel operation, input signal is connected to the RCA inputs. The output connections to the loudspeakers are made through the gold plated brass 5 way connectors. The red (top) connection is positive and the black (bottom) is negative. In this amplifier the black banded output connectors are connected directly to signal ground.

A caveat is in order here – this is a very wide band amplifier with a high input impedance. In order to prevent the output voltage from bleeding back to the input at very high frequencies (thus making a fine power oscillator), keep the input and output cables separate, and don't externally connect the speaker ground to the input ground. Good ground shielding on the input cables is important, and caution is called for in using Litz and other specially low inductance / high capacitance cables. I have not seen a specific example of a problem, but historically it is to be expected when an amplifier's bandwidth exceeds 200 KHz. If the amp makes funny noises, runs extra hot, or blows fuses, this might be an indicator of such an issue.

If you have any questions, just drop me an email: [nelson@passlabs.com](mailto:nelson@passlabs.com)

With everything connected up and the source equipment powered up first, you can proceed to turn on the power switch to the amplifier. Turn-on and turn-off thumps and noise are small in this amplifier, and should not present any hazard to delicate drivers.

At this point you should be able to listen to music. This amplifier has less gain than most (15 dB), but at 25 watts, it's not likely to need it. If you need to turn the gain up on your preamp, then do so. If you can't get enough gain, then you are probably using either the wrong speaker or the wrong amplifier. Talk to your dealer if this is the case.

The power supply of the amplifier is isolated from the chassis and AC earth ground by a thermistor which connects the circuit ground to the chassis and earth ground. This helps to prevent ground loops, but the thermistor stands by to conduct AC line voltage to ground until the fuse blows in case of transformer or other such failure.

The input impedance is 100 Kohms, and the input capacitance is very low, so you should find it easy to drive with tube equipment if you like. The amplifier is largely indifferent to the source impedance of your preamp, so a high source impedance is not a problem.

The amplifier requires about 1 hour of operation to reach normal operating temperature, and this warm-up time is appropriate for the most critical listening, but is not otherwise an issue. The amplifier's final adjustments were made after a 2 hours, and the performance difference between that and cold operation is significant.

I do not personally see a reason to run the amplifier all the time, but you can do that if you want to. The power supply

capacitors are likely to last about 15 years or so, and while they will slowly dry out just sitting there, they will have a shorter life span with the amplifier running constantly. Also, at 180 watts it makes economic sense to shut the amplifier off if you aren't planning on using it for the rest of the day.

Again, the heat sinks on this amplifier run fairly hot, and you want to make sure that they get adequate ventilation. They will run at around 25 degrees C. above the ambient temperature, which puts them around 50 degrees in the average listening room. At this temperature you should be able to put your hand on them for about 5 to 10 seconds or so.

## **Now the following is for your protection –**

Do not defeat the AC line Earth ground connection on the amplifier power cord. It provides an extra barrier to prevent potential shock hazard.

Do not replace the fuse with a type other than specified.

Do not operate the amplifier outside in the weather, or in and around water or anything resembling water. If you spill a drink in the amplifier or if your dog/cat/child urinates on it, turn it off immediately, unplug it, and do not operate it until cleaned by a qualified technician.

If something gets loose or rattles around inside or smells funny, or if you can't touch the heat sinks for 5 seconds or so, then turn it off, unplug it from the wall, and contact First Watt.

There are no user serviceable parts inside. Do not open the amplifier, and if you do anyway, don't operate it with the cover off. There are hazardous voltages inside. If you need to change the operating AC voltage, contact First Watt.

If you have a problem, contact First Watt. We are much happier helping you solve problems so that we can be certain that it's done properly. If you are far away and don't want to ship the product for repair, we will assist your technician with information and parts.

Contact:                    [www.Firstwatt.com](http://www.Firstwatt.com)                    [nelson@passlabs.com](mailto:nelson@passlabs.com)

## Summary of the nominal specifications:

Measured at 120 V AC with a 25 ohm source and an 8 ohm load:

Distortion @ 1 watt	.001% to .005% @ 1 KHz
Input Impedance	101 Kohm
Damping Factor	60
Output power stereo 8 ohms	25 watts @ 1% THD, 1KHz
Voltage Gain	15.3 dB
Maximum unclipped output	+/-20 Volts
Maximum output current	10 amps
Frequency response	- .0 dB @ dB, -1 @ 500 KHz
Noise	~60 uV unweighted, 20-20 KHz
Power consumption	180 watts
Fuse	3AG slow blow type, 2.5 Amp for 120VAC 1.25 Amp for 240 VAC

Warranty: Parts and labor for 3 years, not covering shipping costs or any sort of consequential damages. Warranty coverage is voided for modified products, and repair of modified products is at our discretion.

Copyright 2008 General Amplifier

General Amplifier Inc.  
PO BOX 7607  
RENO NV 89510-7607

[www.firstwatt.com](http://www.firstwatt.com)

## F5 Power Amplifier (As printed in AudioXpress, May 08)

Nelson Pass 1/31/08

### Intro

As many of you may know, First Watt is dedicated to exploring the performance quality of small simple power amplifiers. Over the past four years, five such amplifiers have been designed as concept pieces and produced in limited quantities.

The F1 and F2 explored the possibilities of current source operation with single-stage Class A circuits and no feedback. The Aleph J used JFET devices for the front end of a two stage single-ended Class A amplifier. The F3 achieved very low distortion using power JFETs in a single-stage, single-ended Class A circuit. The F4 demonstrated that an amplifier did not necessarily require voltage gain to be useful.

You can follow the progression at [www.firstwatt.com](http://www.firstwatt.com)

Here is the F5. We want to further push the performance boundaries of simple little amplifiers with a FET two-stage Class A push-pull design.

### A Quickie Tutorial on FET Amplifiers

One of the aims of these articles is to get people to build amplifiers, so here is some tutorial material to get beginners going. I have written up some of this material before ("The A75", Audio Amateur 4/1992), but that was 15 years ago, and maybe it will be helpful to repeat bits of it. All 31 years worth can be found at [www.passdiy.com](http://www.passdiy.com) and related links.

I'm assuming that you understand the concepts of voltage, current, and resistance. If you already know how a FET works, you can skip ahead.

Figure 1 shows an N channel FET, a quantum mechanical black box with three connections. This device is meant to function as a valve, a little bit like a water faucet. In this picture, the Drain (D) of the FET is attached to an electrical power supply, analogous to the pressurized water supply on the other side of the faucet. You can imagine the pipe as wire, and the tank of water as a battery or even a charged-up capacitor.

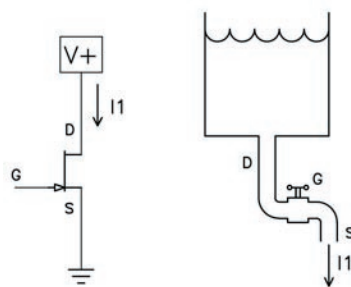

FIGURE 1 FET TRANSISTOR  
VERSUS WATER FAUCET

To continue the metaphor, the voltage of the supply is the water pressure, and the water flowing from the supply is the electrical current. The Source (S) connection of the FET is the output of the faucet. The Gate (G) of the FET is the control pin, and like the handle on the faucet, it controls the amount of electrical current through the FET from the Drain to the Source. For the FET, this control is a function of the relative voltage between the Gate and Source pins. For an N channel FET, raising the Gate positively with respect to Source increases the current flow.

Yes, I know some of you are thinking that maybe the Source should be on top and the Drain on the bottom, but they're not. You might not want to call a quantum mechanic if your plumbing stops up.

The idea that the current going through FET transistor is controlled by the voltage between the Gate and the Source pins remains the key idea, and if you have that firmly fixed, we can leave the waterworks metaphor behind.

FETS come in different types. There are two polarities, N channel and P channel. There are different voltage, current, and power ratings, and different semiconductor processes resulting in JFETs and MOSFETs. In all of them, the current from the Drain to Source is controlled by the voltage between Gate and Source.

A FET is a three pin device, and there are three ways to amplify with them. Figure 2 illustrates these with an N channel FET:

Common-Source (CS) is the connection which can give us both voltage and current gain in a circuit. The input voltage (shown as a little graphical sine wave) goes to the Gate, and the output is taken from the Drain and appears across a resistor between the Drain and the supply voltage. The Source is grounded, and doesn't show a signal voltage, and that's why it's called Common-Source. Note that the output voltage is inverted in phase from the input voltage.

Common-Drain (CD) gives current gain only, and is also known as Source follower, because the output voltage across the Source resistor is nearly identical to the input voltage at the Gate. While the Drain is usually attached to a DC voltage value, the AC voltage is ideally zero, and so it is called Common-Drain.

Common-Gate gives non-inverted voltage gain only, with the input signal going into the Source and coming out the Drain. The Gate is grounded.

Figure 2 only shows what happens to AC signals, but it doesn't illustrate the DC voltage and current values that the FETs need in order to operate. These DC values are often referred to as the bias of the device, and you will hear that word a lot with respect to amplifiers.

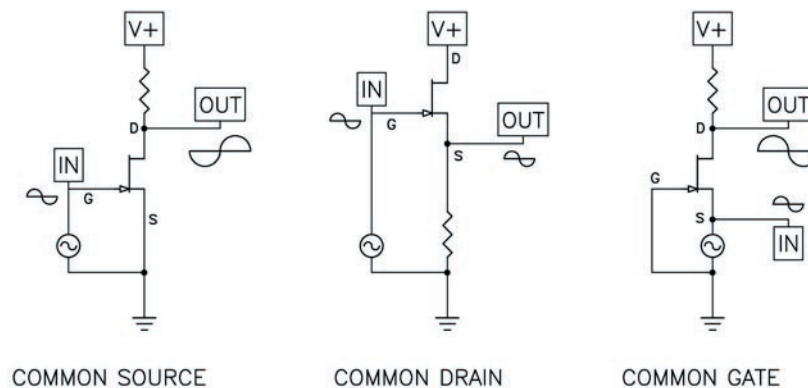

FIGURE 2 THE THREE OPERATING MODES

The optimum bias values vary by the device and the needs of the circuit. In general, to function as an amplifier, the FET needs to have at least a few volts between the Drain and the Source. If the FET is an N channel type, the Drain must be at least a few volts positive with respect to Source. If it's a P channel type, the drain must be negative with respect to Source.

In addition, the Gate of the FET must be placed at a DC value relative to the Source so that the current and voltage of the FET is positioned in the linear region between the extremes of voltage and current – somewhere between all the way on and all the way off. It is in the middle ground where the distortion is low. Generally for N channel JFETs, it is with the Gate

voltage at 0 or slightly negative with respect to the Source, and for N channel MOSFETs the gate voltage is a couple volts positive. One of the important functions of a circuit is to set up the DC conditions of gain stages so that the devices have stable operation in this region. For every amplifying circuit, there will be a “sweet spot” of voltage and current which will give the best overall performance.

Figure three shows some examples of real circuits that illustrate simple Common-Source amplifiers and the bias voltages and currents that would be typical for them. You can build both of these circuits and they will work.

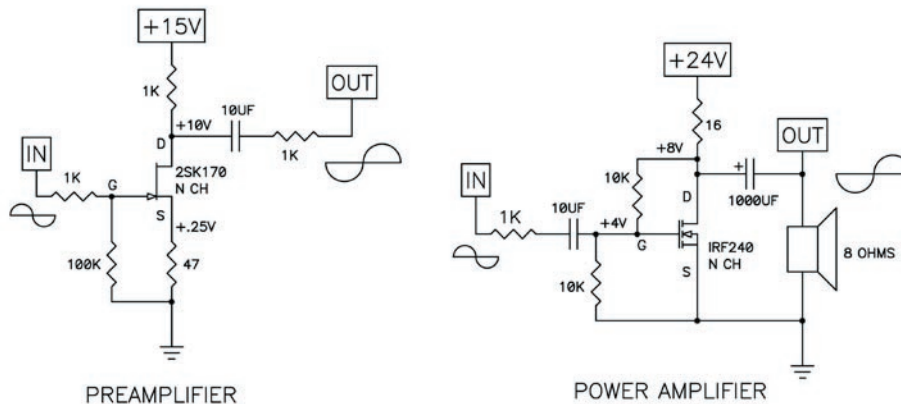

FIGURE 3 COMMON SOURCE EXAMPLES

On the left you see an example of a simple preamplifier stage with a gain of roughly 10 times (20 dB). The JFET is self biased in this circuit: With 5 mA going through the JFET, the gate needs to be at about -.25V with respect to the Source. We put 47 ohms in series with the Source, raising its voltage to +.25V and this conveniently allows us to bias the Gate at 0V DC, or Ground.

On the right, we have a power MOSFET set up as a simple power amplifier, intended to deliver about 1 watt into an 8 ohm loudspeaker. The 16 ohm power resistor performs as a current source to the circuit, and the two 10 Kohm resistors on the input set the DC value for the Gate to about 4 volts get it to conduct a 1 amp bias current. For a more powerful version of this, see Zen Variations #1 (AudioXpress, March 2002)

Figure four shows some real Common-Drain amplifiers, a line-level buffer which can be used in active filters, and a headphone amplifier. In both cases there is no voltage gain in the amplifier, but there is current gain. They both have high input impedance and low output impedance.

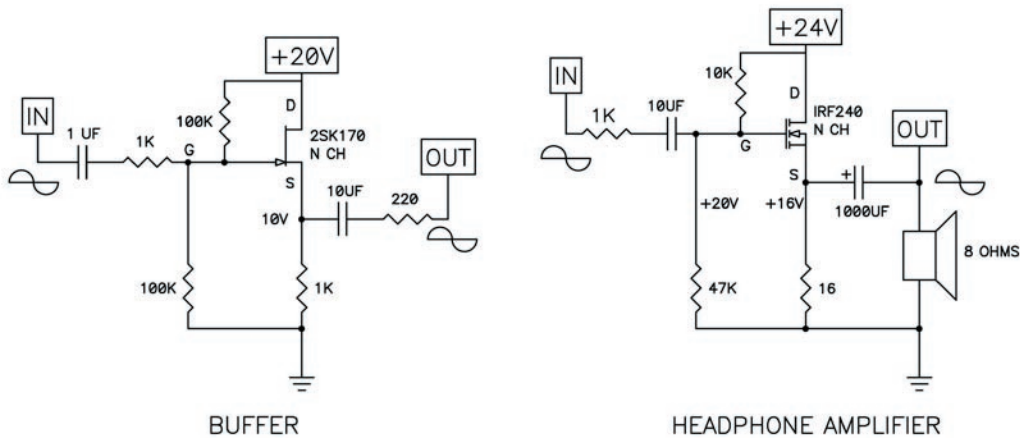

FIGURE 4 COMMON DRAIN EXAMPLES

Common-Gate operation is encountered less often, usually found in “cascode” connection with another device. Discussions of cascoding with good examples are found in Zen Variations 8 and 9 (AudioXpress January 2006, May 2006) and also the article “Cascode Amplifiers” originally published in Audio Magazine, March 1978.

### Simplified F5 Circuit

Figure 5 shows the simplest imaginable version possible of the F5. The topology is familiar; a two-stage conjugate-complementary circuit using two JFET transistors for the input amplification and two power Mosfet devices for the output.

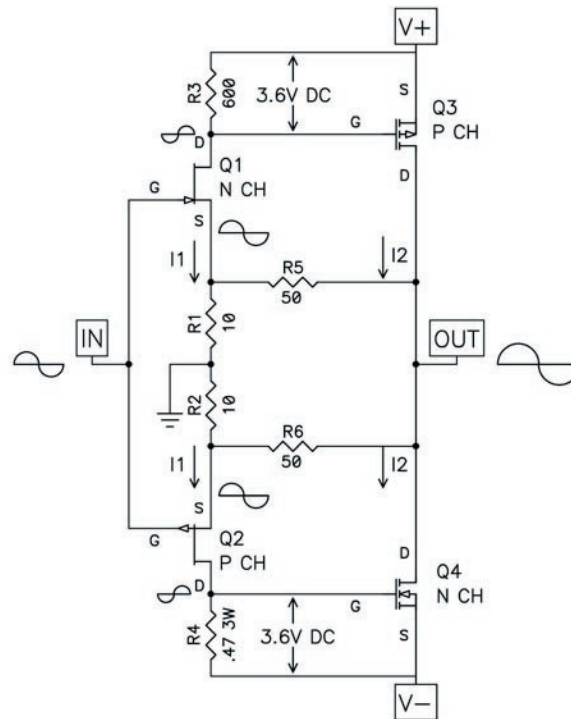

FIGURE 5 SIMPLIFIED CIRCUIT

JFETs Q1 and Q2 form a complementary Common-Source stage, with the input appearing at their Gates and output at their Drains. The JFETs are Class A self-biased at about 6 mA, and so a current I1 comes out of their Drain connections and creates a voltage of about 3.6 volts across R3 and R4, whose values are about 600 ohms. This 3.6V DC value is necessary to bias the power MOSFETs Q3 and Q4 into conduction. The voltage gain of Q1 and Q2 appears across each of these resistors for a gain of about 10 each.

The gain of 10 for the input stage comes from the ratio of the 600 ohms divided by the apparent resistance from the Source to Ground, which is roughly 60 ohms. This 60 ohm number comes from the inverse of the JFET’s transconductance plus the 10 ohm actual resistor. The transconductance for a JFET is the ratio of current change against input voltage change. The gain of this part is typically 0.02 Siemens, or .02 amps per control volt, and if you invert that you get 50 ohms ( $R = V/I$ ). So it looks as if there is 50 ohms inside the part (although there isn’t), and to that we add the 10 ohms of real resistor to get 60 ohms.

Q3 and Q4 do the heavy lifting in this circuit, providing the large output current needed to drive the loudspeaker. The DC voltage appearing from the Gate to Source of these devices is about 3.6 volts, and this biases the MOSFETs to about 1.3 amps.

For this sort of circuit, a 1.3 amp bias means that the amplifier will operate Class A to 2.6 amps of output current. To

understand this, imagine a condition where Q3 and Q4 are idling at 1.3 amps, so that all the current is going from the V+ voltage rail to the V- voltage rail, and none is going through the loudspeaker.

When a positive voltage appears at the Gates of Q1 and Q2, it makes the current through Q1 increase and the current through Q2 decrease. The resulting voltages across R3 and R4 make the current through Q3 increase and the current through Q4 decrease. This makes the output voltage go positive. As the positive input voltage increases, you approach the point at which Q3 is conducting 2.6 amps and Q4 is conducting 0 amps – and all of the 2.6 amps goes through the loudspeaker.

The power of 2.6 amps into 8 ohms is  $I^2 * R$ , or  $2.6 * 2.6 * 8 = 54$  watts. This is the peak value, and the nature of an undistorted sine wave is that the peak wattage is twice the average, so this circuit would operate 27 watts average Class A into 8 ohms. At currents above 2.6 amps one of the transistors will shut off, leaving the other to continue to increase beyond the 2.6 amps in what is known as Class AB.

This circuit employs feedback to improve the performance in a number of ways. Feedback sets the gain, lowers the distortion, improves the bandwidth, and creates the output impedance (damping factor) of the amplifier.

The feedback mechanism for this amplifier is R3 through R6, a dual pair of low impedance voltage dividers which feed the output to the Source pins of Q1 and Q2. Low impedance feedback has been (incorrectly) referred to as “current feedback”, and it is popular in simple high-speed linear circuits. One of the charms of this arrangement is that unlike the classic two transistor differential pair, the drive current available exceeds the bias of the input stage.

Something different about this example is that each JFET has its own feedback – there are two separate feedback loops to this amplifier, so that the loop of Q1/Q3 is independent of the loop for Q2/Q4.

The circuit of Figure 5 illustrates the basics and does in fact work, but has a tendency toward instability. Local parasitic oscillation is often seen, and the bias drifts with temperature, requiring a lengthy adjustment period. This simplified circuit also has no provision for adjusting against the variations to be seen between real FETs that you will encounter.

### Actual Working Circuit

Figure 6 shows a completely functional version of the circuit, with useful enhancements. We have added R7 and R8 in parallel with R5 and R6 so as to share the dissipation, allowing inexpensive 3 watt resistors to do the job.

You never know what the amplifier will be attached to, so the input of the amplifier now sports R9 to avoid parasitic oscillation of the input JFETs, and R10 to ensure that the input has a default reference to ground when there is nothing connected.

R11 and R12 are 3 watt power resistors added to the Source pins of the MOSFETs to increase thermal stability and serve as convenient current sensing elements. R13 and R14 are placed in series with the Gates of the MOSFETs to prevent parasitic oscillations, just as we did with R9 on the input stage.

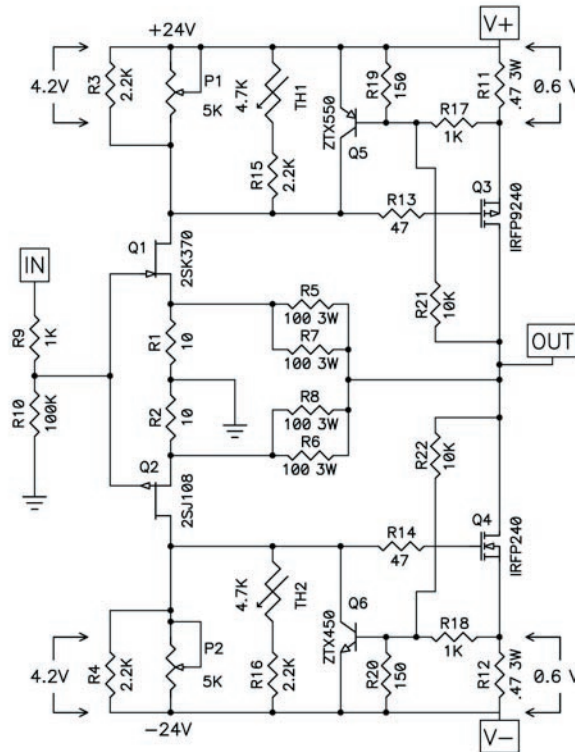

FIGURE 6 F5 AMPLIFIER

R2 and R4 have had their value increased and then placed in parallel with 5 Kohm trim potentiometers P1 and P2. This allows adjustment of the output stage bias current and also the output DC offset.

We can stop here, and the amplifier will be fully functional. The remaining additions will enhance temperature tracking and provide for output current limiting.

Th1 and Th2 are small 4.7 Kohm thermistors that have been placed in series with R15 and R16 respectively. The resistance of the thermistor declines with temperature, and if placed in close proximity to the output transistors will help compensate for thermal drift. You can build the amplifier without them, but you will have a longer warm-up time and you will spend more time adjusting the bias.

On the positive half of the output stage, Q5, R17, R19, and R21 will arbitrarily limit the output of the amplifier in the event that you accidentally set the bias too high or short the amplifier's output. Q6, R18, R20 and R22 do the same for the negative half of the amplifier. The output MOSFETs are easily capable of passing very high currents at the request of Q1 and Q2, and it is wise to set a limit in case of accident.

Understanding the limiting circuit is easy. Q5 and Q6 look at the voltages across the R11 and R12, and will start to conduct when their Base to Emitter voltage exceeds .4 volts or so. At .4 volts Q5 and Q6 draw off enough drive current from Q1 and Q2 to start creating measured distortion, and hard limiting occurs when the voltage driving Q5 or Q6 is increased to .6 volts.

Since the 1.3 amps bias through the .47 ohm Source resistors provides at 0.6 volts already, we have to divide that voltage down so that limiting occurs at a higher current. We do this for Q5 with divider resistors R17 and R19, and for Q6 with R18 and R20. R21 and R22 allow us to also adjust the limit point based on some information from the output voltage.

Where do we want to limit? The amplifier with 24 supply rails should be good for a 50 watt peak into 8 ohms, or about 2.5 amps. For a 4 ohm load we would want 5 amps, and for a 2 ohm load, we want 10 amps. Since we only have two output devices, we probably are best off stopping there.

We will calculate the values as follows, starting with arbitrary values of 1 Kohm for R17 and R19. At 10 amps peak, the voltage across R11 or R12 will be about 4.7 volts. R19 and R21 will be chosen to divide that down to .6 volts, and we solve the formula

$.6V/4.7V = R19/(R17+R19)$       Since R17 is already 1 Kohm, we simplify to

$.127 = R19 / (1000 + R19)$       And we get  $R19 = 150$  ohms

10 amps into a dead short is about 200 watts dissipation on an output transistor, which will probably exceed its rating. R21 adds a “foldback” characteristic to this so that the current value will be lower into a shorted output. To ensure against damage into dead shorts, we want to limit the zero crossing current to about 5 amps, keeping the dissipation just this side of destruction.

Current limiting gets a bad rap in general, but I think it's a matter of where and how the limits are set. If you build this amplifier, you are of course welcome to delete this portion of the circuit, and of course you will not complain if a shorted output lets the smoke out of your amplifier. As it is, you will still be taking some chances with a shorted output.

### Part Selection

The input JFETs used are 2SK170 or 2SK370 for the N channel parts (Q1), and 2SJ74 or 2SJ108 for the P channel parts (Q2). In these cases the Idss selection code is BL, although V and GR types will also generally work fine. The primary thing about these particular parts is the transconductance figure of 20 mS – many of the potential substitutes are much lower at 4 to 10 mS.

The output MOSFETs are the IRF240 N channel type (Q3) and the IRD9240 P channel type (Q4). They will want to have a voltage rating in excess of 50 volts, a current rating of about 15 to 20 amps, and a dissipation of about 150 watts. Comparable parts are widely available, and here I used Fairchild FQA12P20 and FQA19N20C.

The remaining parts can be generic or special as you see fit. I used Dale RN55D type ¼ watt resistors and the 3 watt Panasonic power resistors from Digikey, where you can also get the 4.7 Kohm thermistors and trim pots.

Audiophiles are often concerned about the effects of capacitors in audio circuits, but a quick examination of the schematic will put your concerns to rest.

### Power Supply

The power supply of the tested amplifier is +/-24 volts and should be rated at 6 amps continuous duty, and more than 10 amps peak per channel. Ordinary unregulated supplies will work fine, and if you need suggestions the Zen Variations #5 (AudioXpress, October 2003) and Zen Variations #3 (AudioXpress, August 2002) both have good examples of regulators and the raw supplies that feed them. I recommend rail voltages from 23 to 25 volts.

### Heat Sinking

At 1.3 amps per channel, you will see idle heat dissipation of 62 watts. To keep the temperature rise of the heat sink to 20 deg C. above the ambient temperature, you will want a heat sink rated at about .6 deg C./watt for each transistor. An example of this would be a chunk of finned aluminum, with a series of 2” fins attached to an 8” by 6” base. You will need two per channel.

The output devices need to be intimately attached to the heat sink. The mounting surface on the heat sink should be at least ¼ inch thick and smooth and shiny. You can use silicone pads for insulation, but Mica and silicone grease are the best.

## Initial Adjustment

Before applying power to the amplifier, you will want to set the values of P1 and P2 to their minimum. Verify this with an ohmmeter. When it comes times to “fire” up the amp first time, if you have a Variac, use it, fusing the AC line to the amplifier with a 1A fast blow fuse. Turn the Variac up slowly, and if you haven’t popped the fuse, then go ahead and confirm the rail voltages to the channels.

Each channel does not need to be attached to a load in order to adjust it. If the only load you have is the loudspeaker, I would advise against using it during adjustment. For each channel you will be adjusting P1 and P2 alternately in order to achieve 0 volts DC at the output and .59 volts across R11 and R12. Each time you adjust P1 you will probably have to go back and adjust P2 again, and so I recommend adjusting the pots in half-measures, alternately setting the pots half-way to their voltage goals and measuring the DC values. Unless there is something very wrong, when the output is at 0 V DC, the values across R11 and R12 will be equal.

In spite of the thermal compensation in the circuit, you should assume that there will be drift as the heat sink temperature rises, and you will need to readjust the values over the course of an hour or two. Usually it is best to start out bias adjustment low, at maybe 0.4 mV across R11 and R12 until the amp is warmed up a bit.

You should be able to get the output DC offset down to 10 mV or so, and I would consider 50 mV the highest acceptable figure for this amplifier when warmed up. After the amplifier has been operated for a few weeks, it is a good idea to check and adjust the offset again after the parts have been burned in.

## Measured Performance

The gain of the circuit is 15.15 dB. The input impedance is 101 Kohm, and the output impedance is 0.1 ohms, for a damping factor of 80.

The noise of a properly laid out circuit is about 30 uV with a quiet supply, and raw supply with two 29,000 uF capacitor and 70 mV ripple will give about 100 uV noise (measured in the band from 20 to 20,000 Hertz).

Figure 7 shows the harmonic distortion + noise plotted against output power, taken at 1 KHz into 8 ohms. This is the lowest distortion yet achieved by either a Zen or First Watt amplifier, descending to .001% below 1 watt.

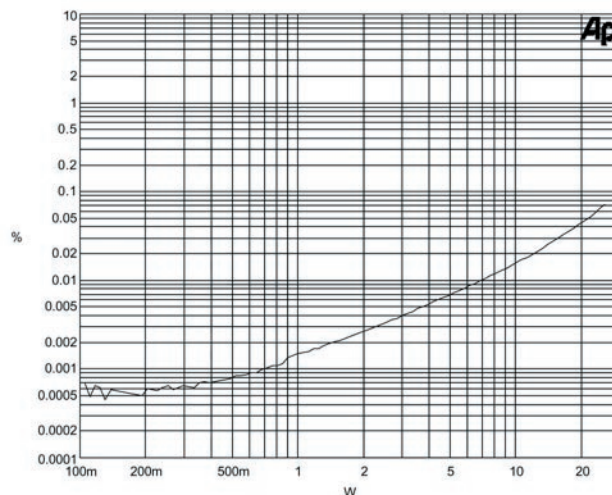

FIGURE 7 DISTORTION VS POWER @ 8 OHMS @ 1 KHZ

Figure 8, spectrum distribution of the distortion at 1 watt, and you can see the dominant 3<sup>rd</sup> harmonic, as well as 2<sup>nd</sup>, 4<sup>th</sup> and 5<sup>th</sup>. The vertical scale is in decibels relative to 1 watt. In this picture, you can also see the noise floor of the system and

amplifier at -135 dB or so below 1 watt.

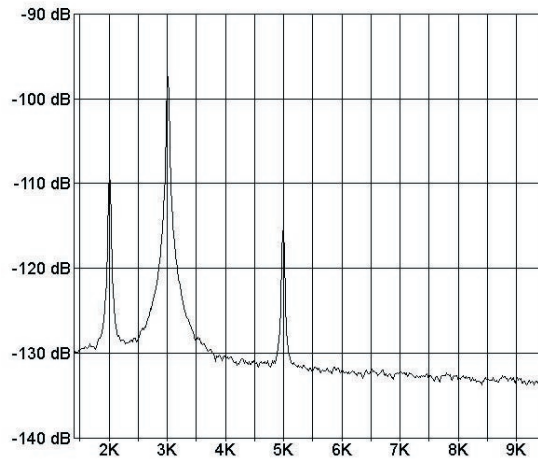

FIGURE 8 DISTORTION SPECTRUM @ 1 WATT @ 1 KHZ

Figure 9 shows the harmonic distortion + noise plotted against output power 4 ohms load, reaching 0.2% at 40 watts.

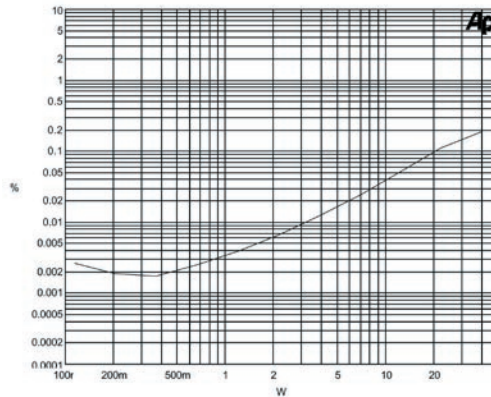

FIGURE 9 DISTORTION VS POWER @ 4 OHMS @ 1 KHZ

Figure 10 shows the harmonic distortion + noise plotted against output power into 2 ohms, where the amplifier begins to clip at 0.3% at 50 watts.

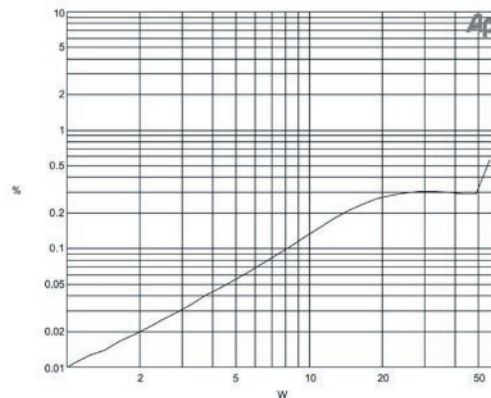

FIGURE 10 DISTORTION VS POWER @ 2 OHMS @ 1 KHZ

Figure 11 shows the distortion + noise versus frequency at 2 watts into 8 ohms.

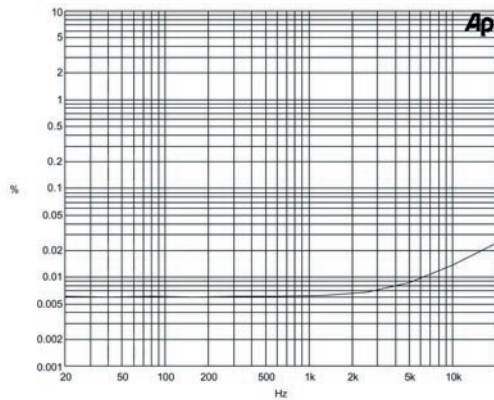

FIGURE 11 DISTORTION VS FREQUENCY @ 8 OHMS @ 2 WATTS

Figure 12 shows the frequency response, flat to DC and down -0.25 dB at 200 KHz.

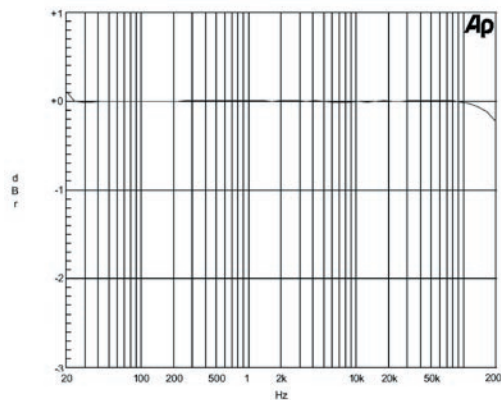

FIGURE 12 FREQUENCY RESPONSE

Figure 13 shows the square wave response at 200 KHz at 1 watt. The amplifier is flat to DC, and -0.25 dB at 200 KHz.

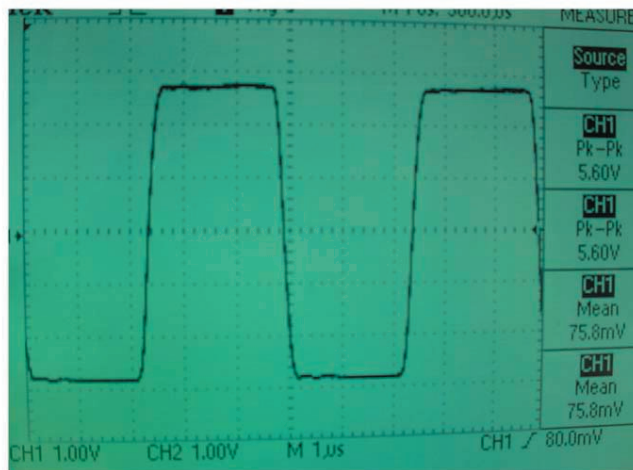

FIGURE 13 200 kHz SQUARE WAVE @ 1 WATT

If you have the equipment to see it, you may find that different gain devices will give you a small peak somewhere just below 1 MHz. I have found that you can trim this by playing with the values of R13 and R14, but as both values approach 0

ohms, you are likely to see parasitic oscillations.

You can additionally limit frequency response with an input capacitor across R10, and also in the feedback loop with capacitance across R5 and/or R8. As you can see, I have chosen not to.

Figure 14 shows the behavior of the amplifier clipping into 1 ohm at +/- 10 amps.

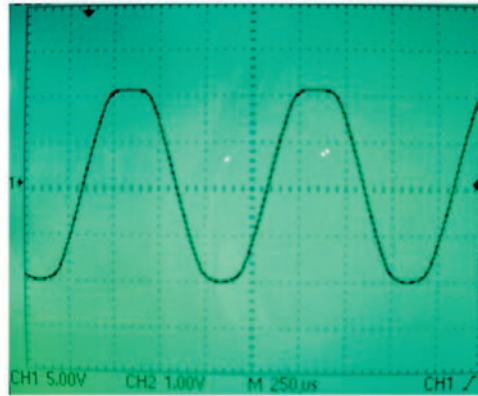
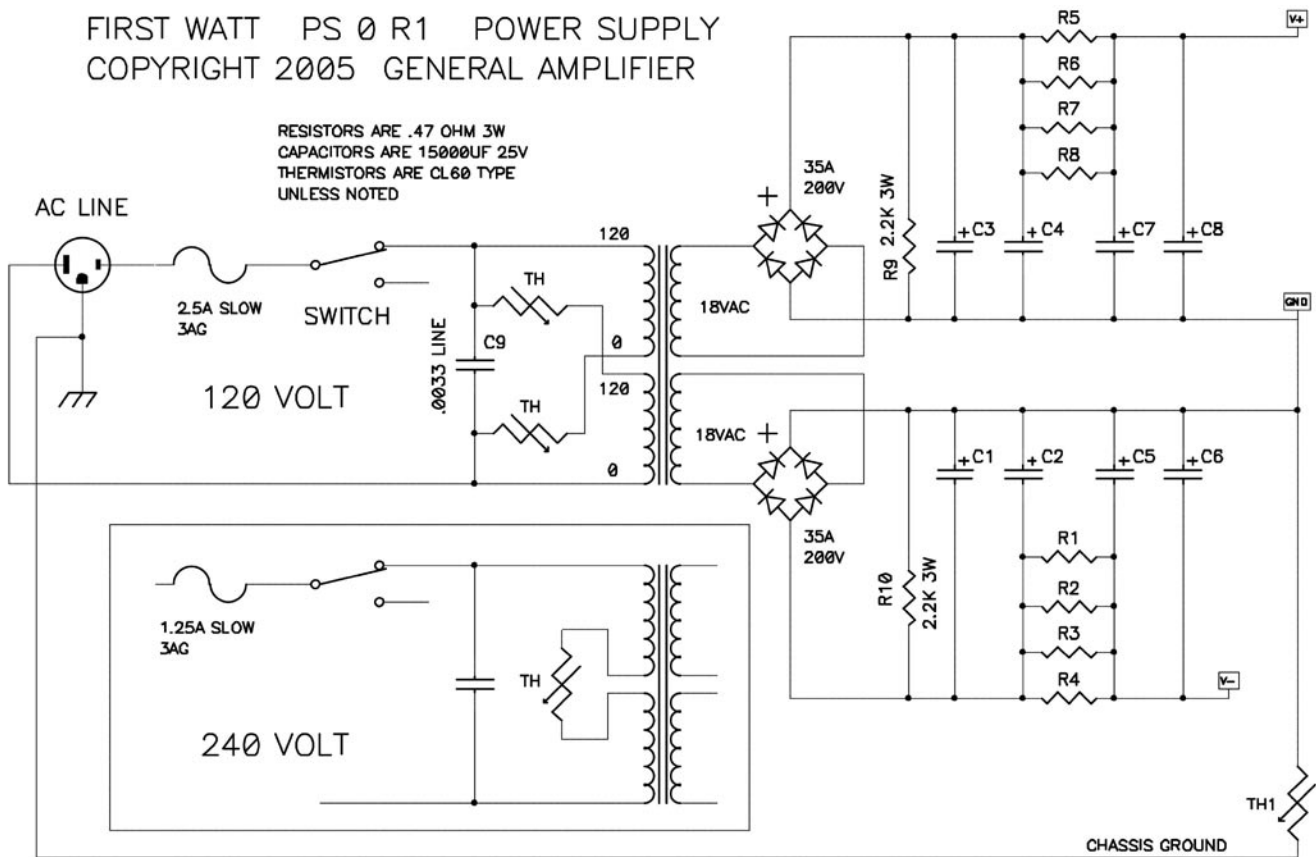

FIGURE 14 CLIPPING INTO 1 OHM

FIRST WATT PS 0 R1 POWER SUPPLY  
 COPYRIGHT 2005 GENERAL AMPLIFIER

RESISTORS ARE .47 OHM 3W  
 CAPACITORS ARE 15000UF 25V  
 THERMISTORS ARE CL60 TYPE  
 UNLESS NOTED



Thermistors in series with the AC line are also used to select line voltages at 120 VAC or 240 VAC, as seen on the front edge of the PC board layout.