

THE hafler PREAMPLIFIER

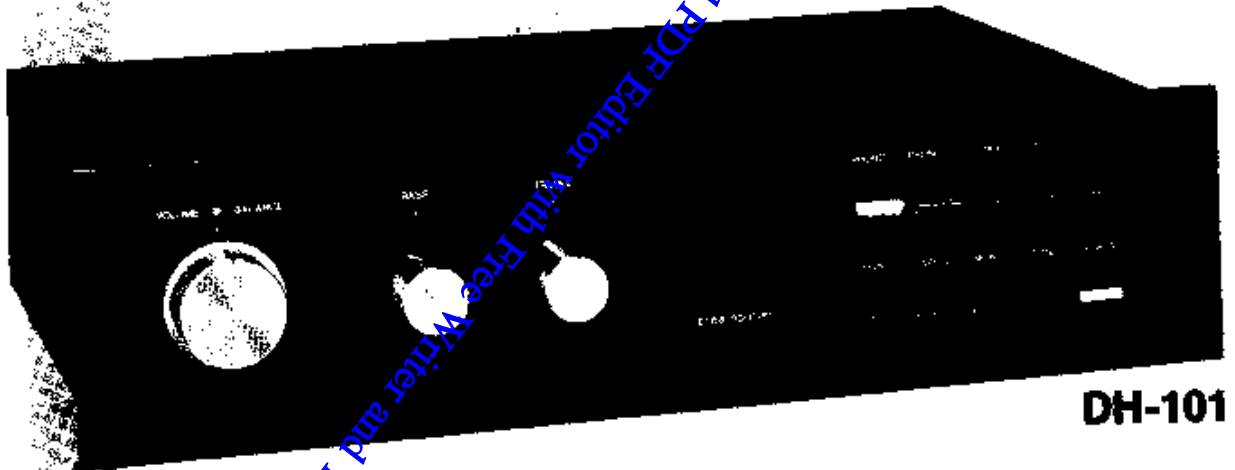

DH-101

INSTRUCTIONS for ASSEMBLY and OPERATION

929001
\$3.00

THE DAVID HAFLER COMPANY
5817 Roosevelt Avenue, Pennsauken, New Jersey 08109

Please refer to this serial
number in all communications
regarding this equipment.
1812829

TYPICAL INTERCONNECTIONS

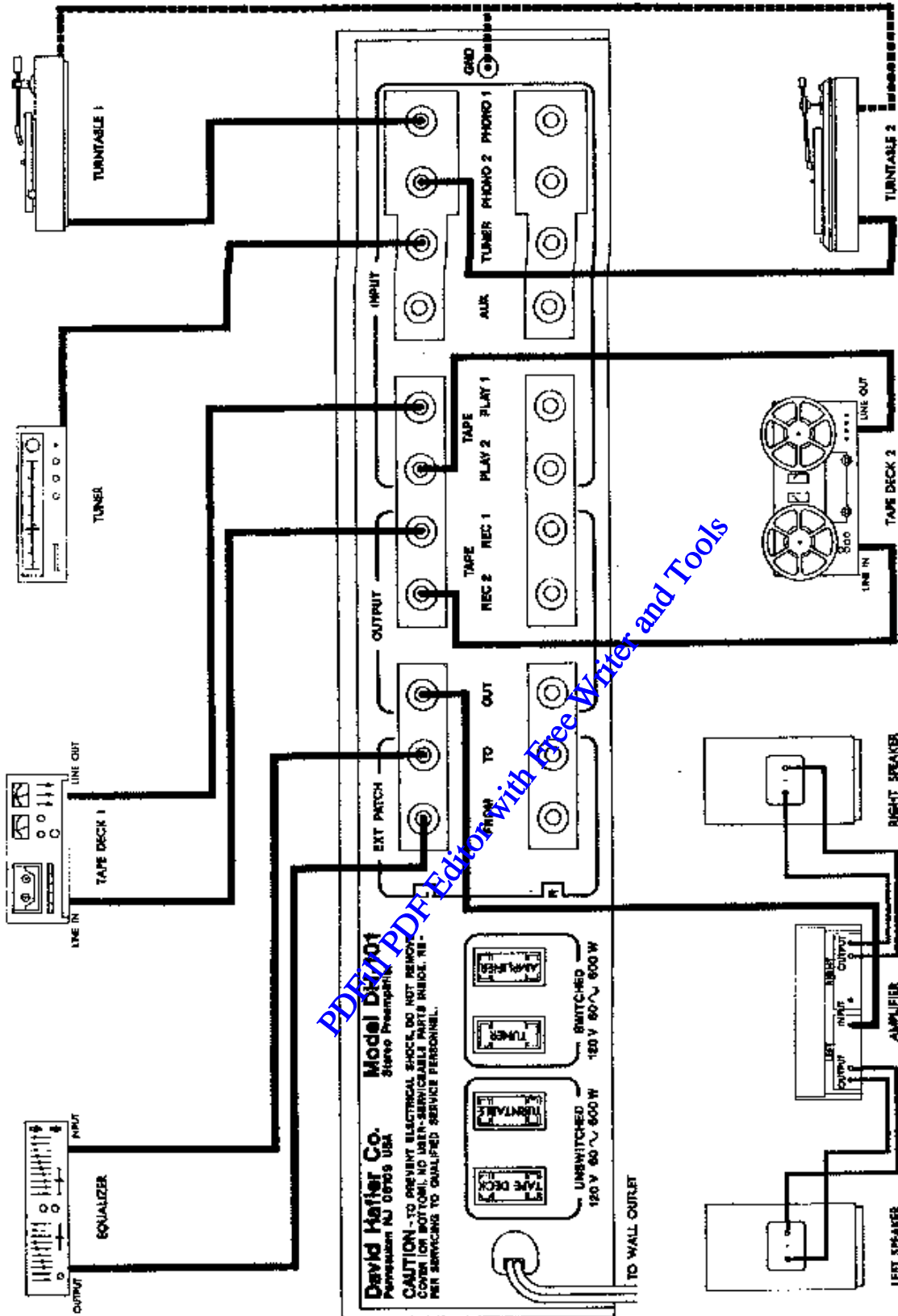

Only Left channel connections are shown for clarity. Right channel is identical.

INTRODUCTION

The Hafler DH-101 is the control center of your high fidelity system. Its extremely low distortion and noise level provides very accurate control of the following functions:

- Preamplification and equalization for such sources as tape recorders, tuners, and the like;
- Control of tonal balance of all signals;
- Adjustment of volume level and balance;
- Switching facilities for all signal sources;
- Tape copying facilities and monitoring capability while tape recording.

The DH-101 uses a novel circuit which is described in more detail in the Technical Section of this manual. This circuit has both theoretical and demonstrable advantages over conventional ones and is responsible for the sonic fidelity of the DH-101. Further, the unit uses very high quality components to ensure that its fine characteristics will be preserved for many years into the future. This quality of performance is combined with a high level of operating flexibility. In order to obtain the full benefits of your preamplifier's capabilities, we urge that you pay careful attention to the installation and operating instructions which follow.

INSTALLATION

All connections to and from the DH-101 are made on the back panel of the unit. Please refer to that, or to the drawing of the installation connections, while reading this section. On that rear panel are eleven pairs of sockets into which the audio input and output plugs are to be inserted. These are arranged in two rows, the upper for the left channel connections, and the lower for the right channel. On the back panel are also four sockets for the ac (power) plugs of the associated high fidelity components.

Inputs — Phonograph

The sockets marked Phono 1 and Phono 2 are identical inputs for the connection of conventional magnetic cartridges (moving magnet, moving iron, variable reluctance, induced magnet, and variable magnetic shunt types). Cartridges having output of 0.5 millivolts per centimeter or higher are suitable. Moving coil cartridges (electrodynamic types) generally require the use of an auxiliary transformer or pre-amplifier; and with the exception of a few which have very high signal output, they have insufficient signal level to be used without the auxiliary equipment.

(The DH-101 has provision for an internal pre-amplifier for moving coil cartridges. This is an accessory Hafler product which can be added to your unit. If your assembled DH-101 includes this accessory, refer to its directions for usage.)

These two sets of sockets permit the use of two separate turntables or two arms on one turntable.

As supplied, the DH-101 has an input impedance which consists of 250 picofarads and 47K ohms in parallel. The capacitance built into the unit along with the added capaci-

tance of the shielded cable from the turntable will give approximately 400 pf which is suitable for practically all cartridges (including transformers and pre-preamps used with moving coil types). For the special unit which might require a lower input capacitance, the built in capacitors of the DH-101 can be removed from the printed circuit boards giving a phono capacitance of less than 200 pf. Refer to the Circuit Description for more information on making this change.

Most phonograph systems have a ground wire to be connected to the preamplifier. Near the Phono input sockets is a terminal for making this connection. However, the need for this grounding connection varies with individual situations. After the system is fully operative, and the phono is the source, experimentation with and without the grounding connection can be tried to determine which is the situation of lowest hum. That is the one which should be used permanently.

Inputs — Tuner/Aux

These two sets of inputs have identical characteristics. They are for use of a tuner and for auxiliary equipment such as TV sound, etc. They handle moderate (line) level signals of 0.25 volts or more and have an input impedance of 25K ohms.

Inputs — Tape Play 1/Tape Play 2

These two inputs for tape recorders are each connected to the output of the respective tape deck. Such outputs are commonly marked "OUT," "TAPE PLAY," "LINE OUT," and similar nomenclature. They normally have signal levels of 0.25 volts or higher. These inputs are not designed for playback directly from a tape head in a deck which has no electronics.

CONTENTS

Operation	Page 4	If Problems Arise.....	20
100, 220, 240 volt AC		Circuit Description	21
Line Connections.....	5	Service and Warranty	22
Assembly Instructions.....	6	Kit Parts List	23
Schematic Diagram.....	12	Specifications	24
Component Value Listing	14	Pictorial Diagram.....	Insert

Outputs — Tape Rec 1/Tape Rec 2

These sockets connect to the recording *inputs* of tape recorders. The signals from these output sockets carry the signals in the DH-101 to the recorder(s). They are not affected by the Volume, Balance or Tone controls, nor by the Mono or Tone switches, nor by ancillary equipment connected to the Ext. Patch facilities. Whichever source is being utilized for the DH-101, such as phono or tuner, its signal is continuously available at these outputs for recording purposes. These outputs are "buffered" so that the characteristics of the inputs of the tape recorders will not have any effect on the signals through the preamplifier.

Outputs — Out

The sockets marked "OUT" provide the controlled signal from the DH-101 and are connected to the power amplifier of the hi fi system. The level and tonal balance of these signals is controlled by the Volume/Balance controls and the Bass and Treble controls. The output of the preamplifier is intended to be used with amplifiers having input impedance of 10K ohms or higher and input sensitivities up to 3.0 volts.

Inputs/Outputs — External Patch

There is a pair of inputs and a pair of outputs marked "EXT. PATCH." These are intended for the use of external signal processing units such as noise suppressors or equalizers. These sockets represent a breaking point in the

circuitry so that external units can be readily connected. The TO connections of the preamplifier go to the IN sockets of the external equipment, and its output is connected to the preamp sockets marked FROM. When there is no external unit, the U-shaped jumpers *must* be inserted between the TO and FROM sockets for each channel. If they are not used, the signal path is broken, and no sound can be obtained through the DH-101.

AC Connections

There are four AC convenience outlets which take the standard American power plugs on the left side of the rear panel. Two are switched on and off with the front panel POWER switch. Two remain energized continuously so long as the power cord of the DH-101 is connected to a power socket. The *switched* sockets should be used for connection of the line cord(s) of the power amplifier and tuner (if one is used). The *unswitched* sockets should be used to energize the turntable and tape recorders. These latter mechanical devices must be turned on and off with their own switching rather than doing it remotely, while it is convenient to leave an all-electronic device such as the power amplifier switched On with its own switch and having it go On and Off when the preamplifier is switched.

Each combined pair of accessory sockets is rated to handle up to 600 watts of continuous power. The switched outlets are limited to handling a surge current of not more than 72 amperes.

OPERATING YOUR PREAMPLIFIER

Your DH-101 has a simple layout of controls arranged in a very functional grouping. However, its apparent simplicity does not limit the flexibility of which the unit is capable. The use of the various controls will be described in turn.

Volume Control

The output of both channels is controlled simultaneously by the volume control, the central knob of the combined volume/balance pair. With typical input sources, the marker line of the volume control will fall between nine and three of the clock face for normal levels of listening.

Balance Control

The outer section of the combined volume-balance control affects the relative level of sound from the two channels, and this affects the localization of the sound source. When the balance control is turned toward the right (clockwise), the sound source will shift toward the right loudspeaker, and vice versa. Balancing is necessary to center the sound relative to the seating position of the listener and also to correct for slight imbalances in program sources.

The control is designed so that near its center of rotation, there is little effect; at further levels of rotation, the effect is much greater until at the end of rotation, the sound comes from one loudspeaker only. Do not hesitate to use the balance control. There is no reason for it to remain always in the center of rotation. Balance so that the sound seems centered in between the loudspeakers from your preferred listening position. Rebalance as required.

Bass/Treble Controls

The bass and treble controls can only be put *in* use when the selector button marked TONE is *in*. When the TONE button is *out*, the tone controls are *out* of the circuit. When the tone controls are centered, you should hear no difference

whether the TONE button is in or out since the tone controls have essentially no effect when they are centered. Clockwise rotation increases the response at bass or treble frequencies while counterclockwise rotation decreases response. The effect of the controls is subtle until they have been rotated far from the center position — where they have maximum effect.

SWITCHES

There are two rows of push button switches. These switches are self indicating as they show a *flag* when depressed. After you are familiar with the switching, you will be able to tell the status of all the switches from a distance by observing the flags.

Phono 1, Phono 2, Tuner, Aux

These switches perform the obvious function of selecting the program source. They are arranged so that only a single source can be played, and other sources are inactivated.

Dub

The DUB switch is used only for the purpose of duplicating tapes from one recorder to another. It connects the output of each recorder to the input of the other, and disconnects them both from preamplifier signals. Then either recorder may be set to *Play* a tape while the other is set to *Record* it. **Caution:** If *both* recorders are set to *Record* simultaneously, and the DUB button is depressed, then a regenerative loop may be set up which will cause recorded squealing. This is not a proper operating condition, for tape dubbing does not require both recorders to be in the record mode simultaneously. However, both recorders can record from other program sources at the same time, and may normally be kept in the *Record* mode. One of them must be changed to *Play* when duplicating tapes.

When the DUB switch is used, it is still possible to listen to phono or tuner or another source. As will be explained below, you can listen to your tape playback only when one of the TAPE selector buttons is depressed. If, for example, you want to listen to a disc recording while going through the tiresome task of copying a tape, you can do this and still have the opportunity to check the quality of the duplicating process when you desire to do so.

Tape 1, Tape 2

The TAPE buttons allow you to listen to your tape player at any time it is operating. You can play a tape, or, if you have a 3-head tape recorder with provision for playing while it is recording, you can monitor the tape while dubbing or while recording off the air or from discs.

Using the DH-101, your tape recorder is always connected in such a way that it is ready to record any program source to which you are listening. If you are listening to a radio program from your tuner, the recorder is always in position to record this as soon as it is turned on in its recording mode. When you wish to listen to the recording, if your recorder has provision for 3rd head monitoring, you merely depress the appropriate TAPE button, and you will hear the recording rather than the source. By alternately releasing and depressing the TAPE button, you can make instantaneous comparisons between the direct source and the taped version.

Remember that activating the TAPE button overrides other functions and you can hear only that tape as a source. Should you find that you cannot hear your phono or tuner selection, check that the tape buttons are not depressed. These show a yellow (caution) flag to alert you.

Mono

The MONO button can be used to change from stereo mode to a combined channel mono mode, mixing the signals of the two channels. The equally mixed signal is then fed to both output channels. It is used for playing mono records or for listening to AM radio or other mono source material.

There are some applications where a partially blended signal is preferable to a mono signal. In such a case, an internal modification can be made. For those interested, write the factory for instructions.

Tone

As indicated previously, the TONE button must be *in* for the tone controls to be *in* operation.

Power

The POWER button turns on the preamplifier, and the fact that it is *on* is indicated by the pilot light which is a small LED (light emitting diode) on the front panel. The POWER button also switches on the associated equipment which is plugged into the SWITCHED outlets on the rear panel. The power switch can handle switching for equipment which requires up to 5 amperes of continuous current and is rated to surge currents up to 72 amperes.

AC LINE CONNECTIONS FOR 100, 200, 220 AND 240 VOLT LINES

The power transformer supplied with the DH-101 has dual tapped primary windings. By arranging these two windings in various series-parallel combinations, line voltages of 100, 120, 200, 220 and 240 volt 50/60 cycle lines can be accommodated. Each primary winding is rated at 120 volts and carries a tap at 100 volts. By paralleling the primaries by tying either the 100 or 120 volt taps together, 100 or 120 volt lines can be accommodated. By connecting the 100 volt windings in series a 200 volt line is accommodated. Similarly connecting a 120 and a 100 volt winding in series accommodates a 220 volt supply. A 240 volt line is accommodated by tying both 120 volt windings in series.

The 1/16 ampere (60ma) slo-blo fuse supplied should be replaced with a 1/32 ampere (30ma) slo-blo fuse for operation with 200 to 240 volt lines.

Line Voltage	Tie Together	Tie Together	Apply voltage to
100	Black and Brown	Black/Red and Brown/Red	Black and Brown combined and Black/Red and Brown/Red combined
	Black and Brown	Black/White and Brown/White	Black and Brown combined and Black/White and Brown/White combined
200	Brown and Black/Red		Black and Brown/Red
220	Brown and Black/White		Black and Brown/Red
240	Brown and Black/White		Black and Brown/White

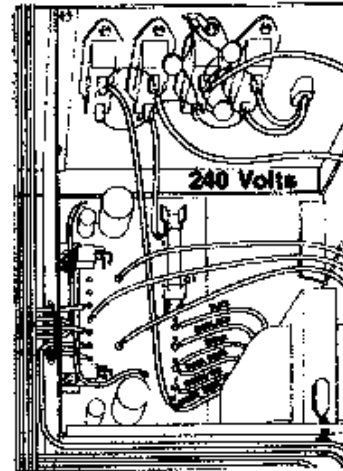
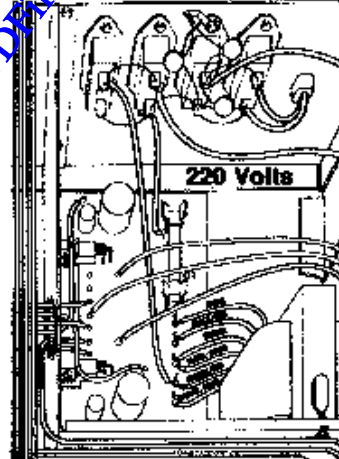
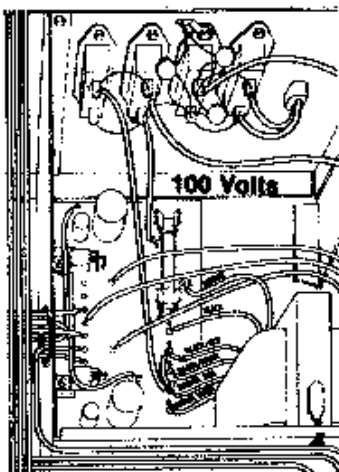

ASSEMBLY INSTRUCTIONS

There are three basic rules for success in electronic kit building:

1. Read the instructions carefully, and follow them in order.
2. Make secure solder connections which are bright and smooth.
3. Check your work carefully after each step.

The DH-101 preamplifier is a versatile component with sophisticated circuitry which has been made remarkably easy to build by individuals with many years of experience in the design and engineering of the finest performing audio kits, and in the preparation of their manuals. The compact size of this preamplifier renders it only slightly more complex in assembly than the simplest designs.

Kit building should be fun, and we are certain you will find this to be so. Assembly will be faster, easier, and more enjoyable if you have someone help you by reading the steps aloud, selecting the required parts, and preparing the necessary wire lengths in advance as you proceed. Fatigue increases the risk of error, so take a break rather than push to early completion. There are relatively few separate components in this design, and the manual has been set up to put most of these into sub-assemblies early in the process, to make it easy to pack everything away, if need be.

Your work area should have good lighting, the proper tools, and a place where the large pictorial diagram can be tacked to the wall within easy reach for checking. The tools should include:

1. A 40 to 60 watt pencil soldering iron with a 3/16" or smaller tip which reaches 700°F.
2. 60/40 (60% tin) ROSIN CORE solder, 1/16" diameter or smaller.
3. A damp sponge or cloth to wipe the hot tip of the iron.
4. A wire stripping tool for removing insulation. This can be a single-edge razor blade, but inexpensive stripping tools are safer, faster and easier.
5. A medium-blade screwdriver (about 1/4" wide).
6. Needle-nose pliers (a long, narrow tip).
7. Diagonal or side-cutting small pliers.
8. Large "gas" or "slip-joint" pliers.
9. A 1/4" "Spin-tite" nut driver may be helpful, but is not necessary.

A soldering "gun" is *not* recommended. The unfamiliar user is more likely to damage the etched circuit boards with its higher heat potential and unbalanced weight. Also, because he may not wait long enough for it to reach operating temperature each time it is switched on, poor solder connections are more likely. Pencil irons are much lighter and easier to use, and there is no waiting time when solder connections follow in sequence, as in kit building. Make sure you have a holder for it, though, and always unplug it when you take a break.

Proper Soldering

There are four steps to making a good solder connection:

1. Make a good mechanical connection to hold the wire in position while heat and solder is applied.
2. Heat the *junction* of the wire and lug, or eyelet, with the bright, shiny tip of the iron.
3. After heating for a couple seconds, apply solder to the *junction*. It should melt immediately and flow smoothly around both surfaces.
4. Allow the connection to cool undisturbed.

Remember that the connection is made by the solder, not by mechanically attaching the wire to the terminal. Usually the wire is looped through the lug and crimped in place, but some prefer to just place it through the hole and rely on the stiffness of the wire to hold it while soldering. This applies more to eyelet connections, of course, or to the small switch lugs which are relatively delicate.

Good solder connections are *essential* for trouble-free, noise-free operation. A good solder joint does not require much solder around the conductors. Never "butter" partially melted solder on the joint, as it is useless. A good connection looks smooth and bright because the solder flows into every crevice when the parts are hot enough. The iron must have a bright, shiny tip to transfer heat easily to the junction. That's why the damp sponge should be used frequently to wipe the tip, and occasionally you must add a small amount of solder to the tip, too. If a connection is difficult to heat, "wet" the tip with a small blob of solder to provide a bigger contact surface to the joint. Once the solder flows around the conductors, any movement must be avoided for a few seconds to allow a good bond. When cool, check the connection by wiggling the wire. If in doubt, or if the connection is not shiny, re-heat the joint. Excess solder may be removed from a connection by heating it and allowing the solder to flow onto the iron, which is then wiped on the sponge.

ALL SOLDER USED MUST BE ROSIN CORE.

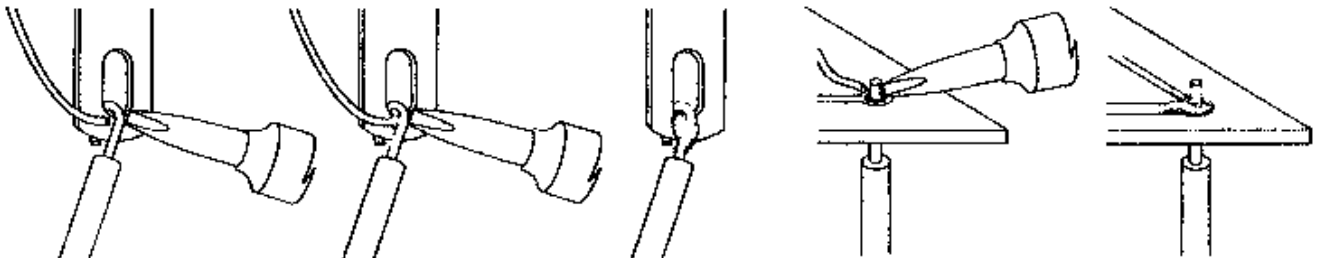

Never use acid core solder or any separate flux in electronic work. Silver solder is also not suitable. If in doubt about unmarked solder, always obtain a fresh supply of rosin core solder. We recommend 60/40 for easiest use. Do not confuse it with 40/60, which is harder to melt.

The general procedure is to use a hot iron for a short time to heat a connection, then add solder with the iron still in contact. Remove the solder once it flows, and then remove the iron. A cooler iron applied for a longer time is more likely to damage components, or lift the copper circuit pattern from the boards. A break in the etched circuit can be mended by simply soldering a small piece of wire across it. Do not allow much build-up of solder on the tip, or it may fall into adjacent circuitry.

When soldering to an eyelet on the board, insert the wire from the components side unless otherwise specified, and apply the iron to the bottom, leaving some bare wire exposed so that you can see that the eyelet is then filled with solder for a secure bond. A round wooden toothpick is provided so that you can heat and clear an eyelet of solder if it hinders your inserting the wire. Some builders prefer to clear every eyelet first with a touch of the iron and toothpick. Others connect the lead by bringing it up to the center of the eyelet on top of the board, applying the iron from the bottom of the board, and pushing the lead in as the solder in the eyelet melts. If the wire has first been "tinned," usually no additional solder is necessary, but it is a good practice to push the wire through, and then back it up a bit, to be sure solder fills the eyelet from both sides. On the bottom of the board, make certain a bright, shiny flow is evident from the wire, across the eyelet, onto the circuit pattern on the board. It is *essential* that the eyelet be fully soldered to the circuitry, too.

In the few connections to the bottom of the board at the end of construction, be sure you leave enough bare wire exposed so that you are able to heat the junction properly, and be sure of a smooth flow of solder around the wire.

"Tinning" refers to the process of applying a light coating of solder to the bared wire end. This secures all the strands, and also makes a good connection easier. Simply touch the wire with the iron for a couple seconds, and apply solder. Allow the excess to flow away onto the iron. When properly done, the wire is uniformly bright, and no larger than before. The hookup wire supplied with this kit does not normally need tinning, for it is pre-tinned.

Wiring the Kit

If any components are unfamiliar to you, checking the pictorial diagram should quickly identify them. Or, the quantities, and the process of elimination as you check the parts list, will help. The pictorial diagram is necessarily distorted to some extent for clarity, so that you can trace every wire in a single overall view for verification as you work. You may wish to check off on the diagram as you solder each location. The diagram is arranged so that a partial bottom view completes all wire connections. In this view the preamp has been flipped toward you over the front panel.

To "prepare" a wire means to cut the designated length from the coil of that color, and strip about 1/4" of insulation from each end. The wire supplied in the kit is #22, so you

can set adjustable wire-strippers accordingly. The transformer leads are #20, and the line cord is #16. Be careful that you do not nick the wire when you strip it (that can happen more easily if you do not use wire strippers) for that weakens it. The wire supplied in this kit is "bonded stranded," which provides exceptional flexibility with resistance to breakage for easier use.

Whenever a connection is to be soldered, the instructions will so state, or indicate by the symbol (S). If more than one wire is to be soldered to the same point, they will be indicated by (S-2), (S-4), etc. If soldering is not called for, other connections have yet to be made to that terminal. They would be more difficult if the connection was already soldered. Every connection in the kit will be soldered when it is complete. A wire which passes through a lug, and continues on to another, counts as two wires in the soldering instructions, so it agrees with the pictorial representation. After soldering a connection, it is best to clip off any excess lead length to minimize the possibility of a short circuit (as in switch areas, where terminals are very close together), and for neatness.

Be sure that uninsulated wires cannot touch adjacent terminals or the chassis metalwork. The one exception is the bare ground wire which is "woven" through successive short ground lugs on the input socket strips on the back panel. So long as it does not touch the long lugs, it is not critical.

The symbol (#) indicates a connection is to be made to that point. When a lug number is specified without (#), it is simply a locating reference.

When the instructions call for twisting two or three wires together, the length of wire indicated anticipates a fairly tight, uniform twist by hand, of three full turns every two inches for a bundle of three wires, and four full turns every two inches for a pair of wires. If you find the wires too short, loosening the twist will gain the needed length.

Handle the circuit boards carefully. They represent a major part of the kit cost. Stand-up components, such as transistors, should be checked when you unpack the board, to be sure all leads are separated. Be particularly careful of the switch lugs, as flexing can break them. If you do break one, it is possible, but not easy, to solder the connection to the stub at the molded switch case.

All of the active circuitry is contained on the PC-4 board, which has been carefully tested to assure that it meets every specification. Only the interconnection of switching and power supply elements is left to the builder. Take the time to be accurate and neat, and you can be sure that your completed preamplifier will meet the performance of a factory assembled unit, and can continue to perform properly for years to come. Check your work, and make sure the entire step has been completed before placing a check mark in the space provided, and continuing on to the next step.

KEP nuts have been supplied as a convenience. These have lockwashers attached, and the lockwasher always goes onto the screw first. If the sheet metal screws have hex heads, you may find it easier to first start them with a regular screwdriver, to set the thread, and then use the more convenient nut driver, if one is available.

MECHANICAL ASSEMBLY

- 1 When you unpack your kit, note that the black front plate is bolted to the front panel of the chassis with a single nut. Disengage these, and replace the nut loosely on the front plate stud. Set these and the black cover aside until assembly is completed. Remove the bolt and the sheet metal screws which secure elements of the chassis assembly for shipping security. These hardware items should be placed with and counted as other similar items in the kit. Check off the components against the parts list, and separate the individual hardware items. An egg carton is ideal for this.

A "set" of hardware includes one screw and one KEP nut with attached lockwasher. Always install the side with the lockwasher first. Use the smaller #4 hardware unless #6 is specified, as in the following step. The screw is always inserted from the outside of the chassis unless otherwise specified. Set aside the four black sheet metal screws, which will be used to secure the cover.

- 2 Select four sets of #6 hardware, the four rubber feet, and the bottom plate. The three dimpled holes are for later mounting of the accessory "head amplifier." The dimples are raised inside the chassis, so the feet mount on the opposite side of the plate, through the remaining four *inner* holes. Insert a screw through each foot so the screw head is recessed, and secure it with a nut on the inside. Set this aside until construction is completed.
- 3 Select the four knobs, the four set screws, and the "J" shaped Allen wrench. Place a set screw on the end of the wrench, and thread it all the way into one of the knobs until two or three threads are exposed in the center, to clear away any debris. Back the screw out until the shaft hole is clear. Install the remaining set screws in like manner, and set the knobs and wrench aside until completion.
- 4 Select the black back panel, the four AC outlets, one of the solder lugs, and eight sets of hardware. Note the location and orientation of the solder lug on the pictorial diagram, and install that outlet and the lug first. The paint should be masked from the inside of the hole to which the lug is mounted. If necessary, scrape it bright to make a good ground connection. Insert each screw first through the panel, next through the outlet flange *behind* the panel, then the lug. Install all four outlets from the inside. Tighten each nut securely, and bend the lug up away from the panel.
- 5 Select the two multiple input socket strips and eight sets of hardware. There is only one orientation of the strip where all the holes align. Insert each screw through the panel first, and mount the strip on the *inside*. Install all sets on each strip before tightening the hardware. Make *certain* the phono sockets do not touch the back panel.
- 6 Select the remaining #6 screw and a nut, the remaining solder lug, and the knurled round nut. Place the

solder lug on the screw, and insert it from the *inside* of the back panel at the hole marked "GND." The metal should not be painted under the lug. If necessary, scrape it to make a good ground. Position the lug as shown in the pictorial diagram, and bend it away from the panel. Tighten the regular nut on the outside to assure a good contact. Then thread the round nut onto the screw until it is snug, and temporarily set the panel aside.

- 7 Select the large "L" shaped brace and the two rubber grommets. Install a grommet in each large hole in the brace.
- 8 Select the power transformer and two #6 nuts. Position the transformer so that the group of three red wires is nearest the short end of the brace when the transformer is mounted on the inside of the "L." Install the transformer through the holes in the brace, and tighten these nuts securely.
- 9 Select the PC-1 power supply circuit board assembly, two sets of hardware, the two mica insulating washers (one round, one rectangular), the nylon screw, and an additional nut. The board is to be mounted on the inside of the brace, adjacent to the transformer. The board mounts below the brace flanges, and one flange slips between the top of the board and the two integrated circuits (ICs). Place the rectangular mica washer underneath the (—) IC (near eyelet 3) so it is insulated from the metal. Insert the nylon screw first through the IC, next through the *round* mica washer, followed by the rectangular mica insulator, then the flange, and the circuit board, and secure it with a nut. No insulator is needed on the other IC, so it is in-

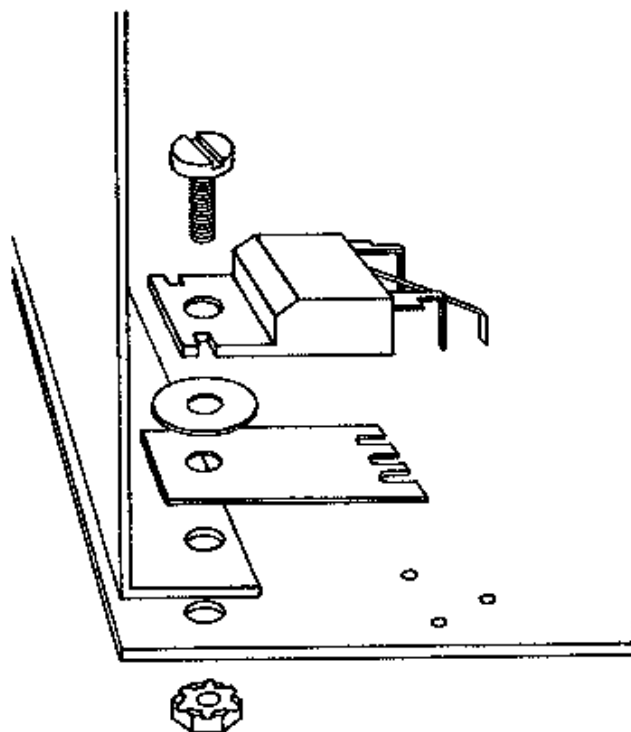

stalled with conventional hardware, as is also used in the third mounting hole. There is no problem if the two nuts under the board contact the adjacent circuitry on the board, for it is all at ground potential. Set this assembly aside temporarily.

- 10 Select the two switch circuit board assemblies, the switch mounting bracket, and four #4 screws. The switch mounting holes have extruded threads, so no nuts are needed. The switches are assembled so that the bracket flanges project toward the pushbuttons. The circuit boards face each other in the center, with the perforated switch lugs facing out. It is easiest to start one screw in each switch first, and then slip the bracket between the screw head and the switch frame. The last two screws are then easier to install. Be sure all four are tight. Be careful not to damage the push-button assemblies.

INITIAL WIRING

The basic mechanical assembly has been completed, so there are not many separate pieces remaining. A soldering iron will be used regularly from now on. If you are not familiar with electronic kit-building procedures and terminology, such as "tinning," "preparing a wire," "wetting" the iron, and the specifics of soldering — especially to eyelets — read the preliminary instructions again. The proper performance of so sophisticated a circuit as this makes good connections mandatory, and its compact size makes it a bit more difficult to find and correct any problem later. This is not a difficult kit to build, but it is somewhat complex, so whenever you feel tired, unplug your soldering iron, close up shop, and take a break.

- 11 Prepare a 9" black wire. Connect one end to eyelet #5 in the top front corner of the larger switch board, PC-3. (S).
- 12 Select the short piece of power cord. Separate the two conductors for 1" at one end, and cut off an additional 1/2" from one conductor. At the opposite end, separate the two conductors for 1-1/2", and cut off 3/4" from one (either) conductor. Prepare all four ends by stripping 1/4" of insulation from each, twisting the strands tightly together, and tin them. This is important so that loose strands cannot contact adjacent surfaces. Connect the lead at the first end which is only 1/2" shorter to lug #2 of switch ST. Connect the adjacent lead to ST lug #3. Position these, and the wire from step 11, past the back of the assembly.
- 13 Be sure you have separated the .1 disc capacitors from the .01 capacitors. Select one of the .01 mfd discs, and trim each lead to 1/2". Connect one lead to ST lug #3. (S-2). Connect the other lead to ST lug #2. (S-2). Be sure that all strands on each lug are soldered. Place the capacitor flat against the switch body.
- 14 Select four sheet metal screws, the main U-shaped chassis, and the switch assembly. Install the switch assembly from the inside of the chassis so that the power

switch and cord are next to the outside edge. Set this aside temporarily.

- 15 Select the back panel assembly and the long piece of bare solid wire. When a short lug is called for on the input socket strip, it will always be identified by the numbers of the adjacent lugs, as #6-7, located between lug 6 and lug 7. Cut a 12" piece of wire and thread it through short lug #6-7. Solder the approximate center point of the wire to lug #6-7. Then take one end of the wire and "weave" it through successive short lugs #5-6, #4-5, #3-4, and stop at #2-3. Use loops of 1/4" or more radius, as in the diagram, for plenty of clearance around each long lug. Solder each short lug after you have formed its loop properly. Cut off any excess wire at lug #2-3. (S). Now weave the other end of the wire through lugs #7-8, #8-9 and #9-10, looping it as before and soldering each as you go. Finally loop and connect it to lug #10-11, but do not solder this lug yet. Cut off excess wire.
- 16 Cut another 12" bare wire, and solder the center point through short lug #17-18. Following the same procedure as before, solder all the short lugs #13-14 through #20-21 together. Connect the wire to lug #21-22 as well, but do not solder it yet. Cut off excess wire. Do not discard the bare wire that remains.
- 17 Select one of the .1 mfd capacitors. Thread one lead through short lug #0-1, loop it around lug 1, and connect it to short lug #1-2. Solder lug #1-2 only. Cut the other lead to 1/2", and connect it to the solder lug between lugs 1 and 12.
- 18 Select the remaining .1 mfd capacitor. Thread one lead through short lug #0-12, loop it around lug 12, and connect it to lug #12-13. Solder lug #12-13 only. Cut the other lead to 1/2" and connect it to the solder lug as before. (S-2). Make sure the bare leads of the capacitors do not touch the mounting hardware, and place the capacitors close to the panel.
- 19 Strip a 2-3/4" piece of black wire bare. Weave it through AC outlet lugs #5, #6, #7 and #8. Solder #5 only. No loops are wanted in this wire.
- 20 Select a .01 mfd capacitor. Trim its leads to 3/4". Connect one lead to AC lug #7. Place the capacitor down between the outlets, and connect the other lead to the solder lug adjacent to AC lugs 2 and 3.
- 21 Select another .01 capacitor, and trim its leads to 1/2". Connect one lead to the solder lug. (S-2). Connect the other lead to AC lug #3.
- 22 Strip a 1" piece of black wire bare. Connect one end to AC lug #3. Connect the other end to AC lug #4.
- 23 Select the remaining .01 capacitor, and cut its leads to 3/8" or less. Connect one lead to AC lug #3. Connect the other lead to AC lug #7. (S-4). (One through wire)

- 24 □ Select the AC line cord and the strain relief. Separate the two conductors for 1-1/2". Strip 1/4" of insulation from each conductor if it has not been stripped as supplied, twist the strands of each tightly, and tin each end. Make a sharp "V" in the cord 2" from the bared ends, by bending the cord sharply back on itself. Install the strain relief as shown in the detail drawing. The small end of the strain relief is nearest the stripped end of the wire. Crimp the two halves of the strain relief together around the wire with heavy pliers to partially form it before insertion into the back panel. Then grip the larger portion of the strain relief with the tips of the pliers, squeeze it tightly, and insert the end of the cord, and the strain relief, through the panel hole from the outside. Note the hole has a flat on top, and the strain relief is installed so that the cord is vertical. It snaps into position when it is fully inserted.

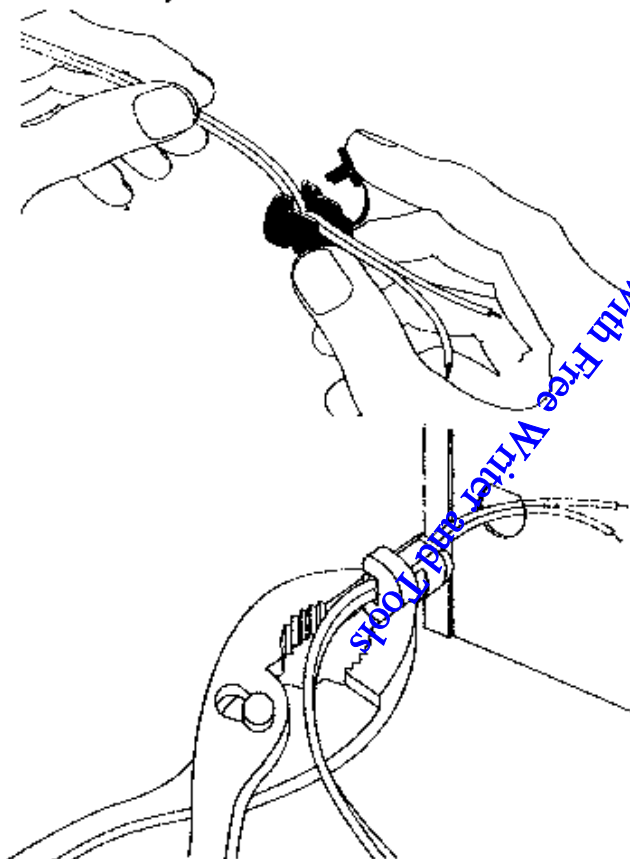

- 25 □ Connect one conductor of the line cord to AC outlet lug #4. (S-2). Connect the other conductor to lug #8. (S-2).
- 26 □ Prepare a 2" green wire. Connect one end to AC outlet lug #6. (S-3). (One through wire)
- 27 □ Strip a 1" piece of black wire bare. Connect one end to AC outlet lug #1. Connect the other end to AC lug #2. Make sure this wire is crimped securely around each lug, as it will not be soldered in position for some time.

You will now connect a number of long wires to the back panel. Those to the upper group of input sockets (1 through 11) should be connected from the top of the panel, and those to the lower sockets from the bottom of the panel. After soldering, each wire should be tucked down along the edge of the panel, extending to the right, past the AC outlets. To conveniently identify each wire later, a set of self-adhesive numbers is supplied with the kit. Near the opposite end of each of these wires, attach the number corresponding to the socket number to which it is connected. For easier removal later, allow the halves of the tape to join at an angle, rather than in line. However, the first two black wires, which are connected to short ground lugs, will *not* be so identified.

- 28 □ Prepare a 6" black wire, and connect one end to input socket *short* lug #10-11. (S-2).
- 29 □ Prepare another 6" black wire, and connect it to input *short* lug #21-22. (S-2).
- 30 □ Prepare a 20" green wire, and connect one end to input socket #11. (S). Install tag #11.
- 31 □ Prepare a 19" red wire, and connect it to socket #22. (S). Don't forget the wire tag.
- 32 □ Prepare a 13" red wire, and connect it to socket #10. (S).
- 33 □ Prepare an 11-1/2" green wire, and connect it to socket #21. (S).
- 34 □ Prepare a 12" green wire, and connect it to socket #9. (S).
- 35 □ Prepare an 11-1/2" red wire, and connect it to socket #20. (S).
- 36 □ Prepare a 12-1/2" red wire, and connect it to socket #8. (S).
- 37 □ Prepare a 14-1/2" black wire, and connect it to socket #19. (S).
- 38 □ Prepare a 13-1/2" green wire, and connect it to socket #7. (S).
- 39 □ Prepare a 15" red wire, and connect it to socket #18. (S).
- 40 □ Prepare a 14-1/2" red wire, and connect it to socket #6. (S).
- 41 □ Prepare an 18" black wire, and connect it to socket #17. (S).
- 42 □ Prepare a 15" black wire, and connect it to socket #5. (S).
- 43 □ Prepare an 18-1/4" green wire, and connect it to socket #16. (S).

- 44 Prepare a 16" green wire, and connect it to socket #4. (S).
- 45 Prepare an 18-1/2" red wire, and connect it to socket #15. (S).
- 46 Prepare a 16-1/2" red wire, and connect it to socket #3. (S).
- 47 Prepare an 18-1/2" green wire, and connect it to socket #14. (S).
- 48 Prepare a 7-1/2" black wire, and connect it to the *short* lug #0-1. (S-3). (One through wire). This wire, and the one in the next step do not have identifying number tags. The tags are no longer needed.
- 49 Prepare a 7" black wire, and connect it to *short* lug #0-12. (S-3). (One through wire)

This completes the back panel sub-assembly wiring, and the kit is now nearly half completed. Set the back panel aside, and select the main chassis and switch assembly.

MAIN CHASSIS WIRING

When making connections to the switch lugs, because of the narrow spacing, you may prefer to minimize the risk of shorting to adjacent lugs by simply inserting the wire through the lug and soldering, rather than bending a hook in the wire and crimping it in place first. Without the hook, you need strip only about 1/8" of insulation from the end of the wire. It is important that no long bare ends be able to touch adjacent lugs, so always clip off any excess after soldering.

Be careful that you do not put excessive strain on these rather delicate switch lugs. If it is necessary to move wires after they have been fastened to the lugs, hold the lug with your needle nose pliers while you do so.

When a connection to a switch lug is not soldered immediately, as in the next four steps, because other wires will be added later, you should strip the 1/8" of insulation on these, so they may be hooked in place later, after soldering, you may want to clip off the hook for plenty of separation.

- 50 Prepare a 5-1/4" black wire, and connect one end to switch SQ lug #11. (S). Place this wire across the back of the two switch boards, and around the outside of switch SE, and connect the other end to SE lug #10. Crimp it securely.
- 51 Prepare a 5" red wire, and connect one end to SQ lug #5. (S). Be sure this bared end does not short to lug 6. Connect the other end to SE lug #4, and crimp it.
- 52 Prepare a 5-1/4" green wire, and connect one end to SP lug #11. (S). Connect the other end to SE lug #7, and crimp it.
- 53 Prepare a 5" black wire. Connect one end to SP lug #5. (S). Be sure this does not short to lug 6. Connect the other end to SE lug #1, and crimp it.
- 54 Prepare a 6-1/2" green wire, and connect one end to
- SP lug #8. (S). Bring the other end around the outside of switch SE, and connect it to SE lug #12. (S).
- 55 Prepare a 6-1/2" black wire, and connect one end to SP lug #2. (S). Place this wire around the outside of switch SP, and connect the other end to SE lug #6. (S).
- 56 Strip bare a 1/2" piece of wire. Connect it across switch SR between lugs #2 and #8. Solder both lugs.

Set the main assembly aside temporarily, and select the power supply assembly. When you connect transformer leads, they may be shortened for neatness, but be sure that they are not made too short if there is a possibility that different wiring may be chosen for another line voltage in the future. These instructions specify the connections for 120 volt AC power, as used in the United States. Alternative wiring for use with either 50 or 60 Hz current at 100, 220 or 240 volts AC is described on page 5. Such changes are limited to the connections to PC-1, eyelets 2, 5, 6, 7 and 8.

When more than one wire is to be connected to a given number eyelet, be sure the eyelet is fully cleared of solder to provide sufficient space. The wooden toothpick is helpful for this purpose. Always be certain that a smooth solder connection is made from the wire to the eyelet, and *across the eyelet to the circuitry on the bottom of the board*. If the eyelet is not well soldered to the circuitry, an intermittent connection may later develop. Some of the eyelets on the power supply board are simple "tie points" for unused transformer wires, and for this reason they make no direct connection to the circuitry. Note that the #11 position is actually a series of seven eyelets, all connected at ground potential, and interchangeable. Specified wire lengths assume these eyelets will be used in succession, starting nearest the transformer (front), except that the larger eyelet in the center of the group is intended for the heavier transformer lead.

Wires connect to the eyelets on the top (components) side of the board, and are soldered from the bottom.

- 57 Select the Brown/Red transformer lead, trim and prepare it as necessary, and connect it to PC-1 eyelet #7. (S).
- 58 Prepare a 1-1/2" black wire, and form it into a 3/4" wide "U". Bend it sideways in the center to clear the Brown/Red lead, and connect this jumper from eyelet #6 to eyelet #8.
- 59 Select the Brown/White lead, and trim it as needed. Connect it to eyelet #8. (S-2).
- 60 Select the Black/White lead, trim as needed, and connect it to eyelet #6, but do not solder.
- 61 Prepare a 4-1/2" red wire, and connect one end to eyelet #6. (S-3). This is the most difficult step in the kit. It may be necessary to attach this wire to a bare section of one of the other wires at eyelet #6. Be sure all are soldered together securely. Place this wire to the rear, between the fuse clips and the tall capacitor.

Proceed to page 15

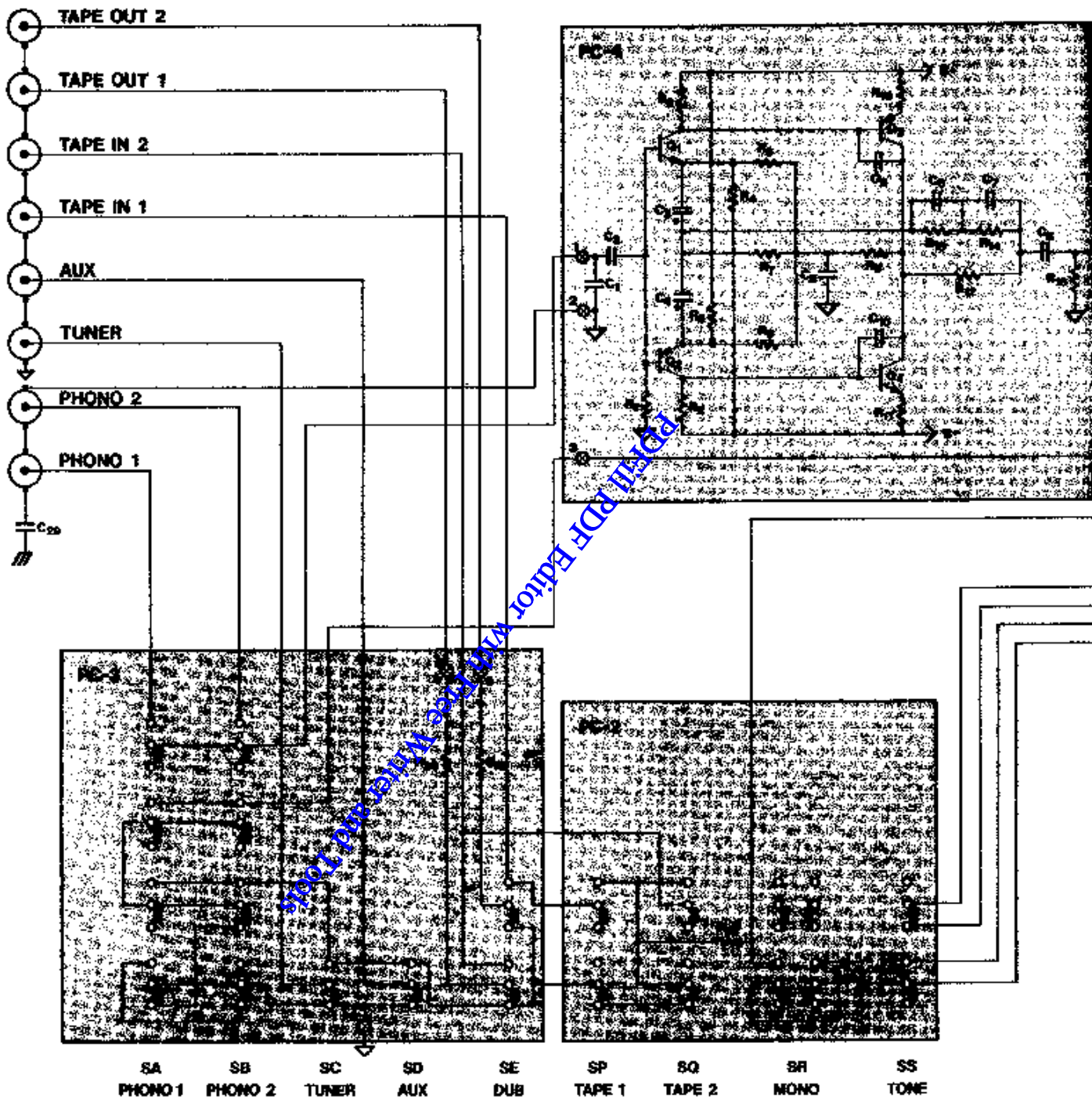

SCHEMATIC DIAGRAM

Left channel shown
right channel identical.

© Copyright 1978. All rights reserved.

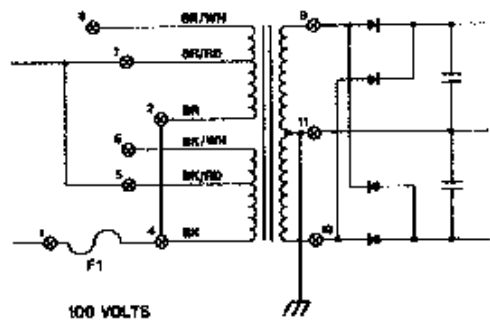

100 VOLTS

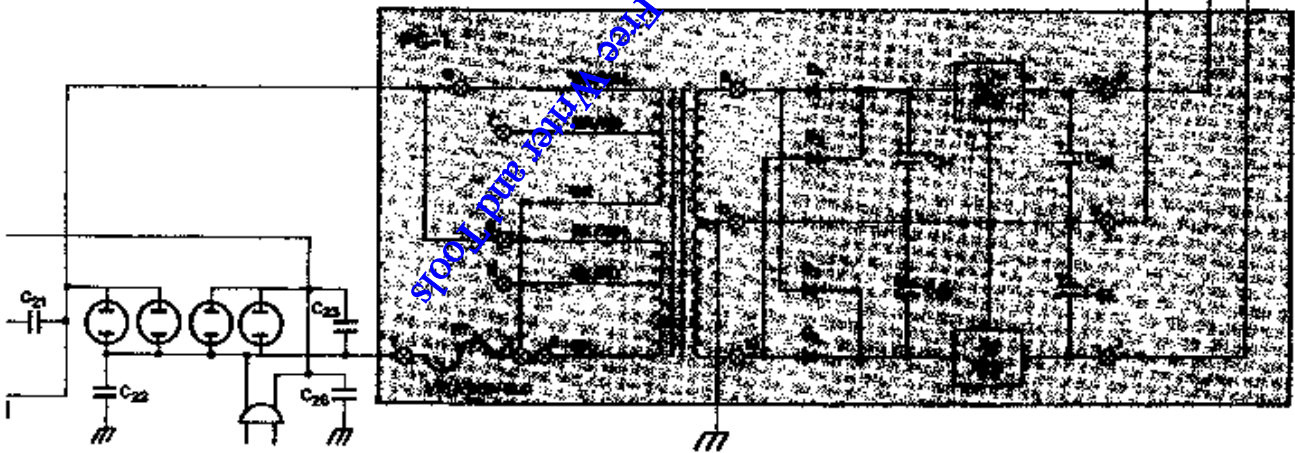
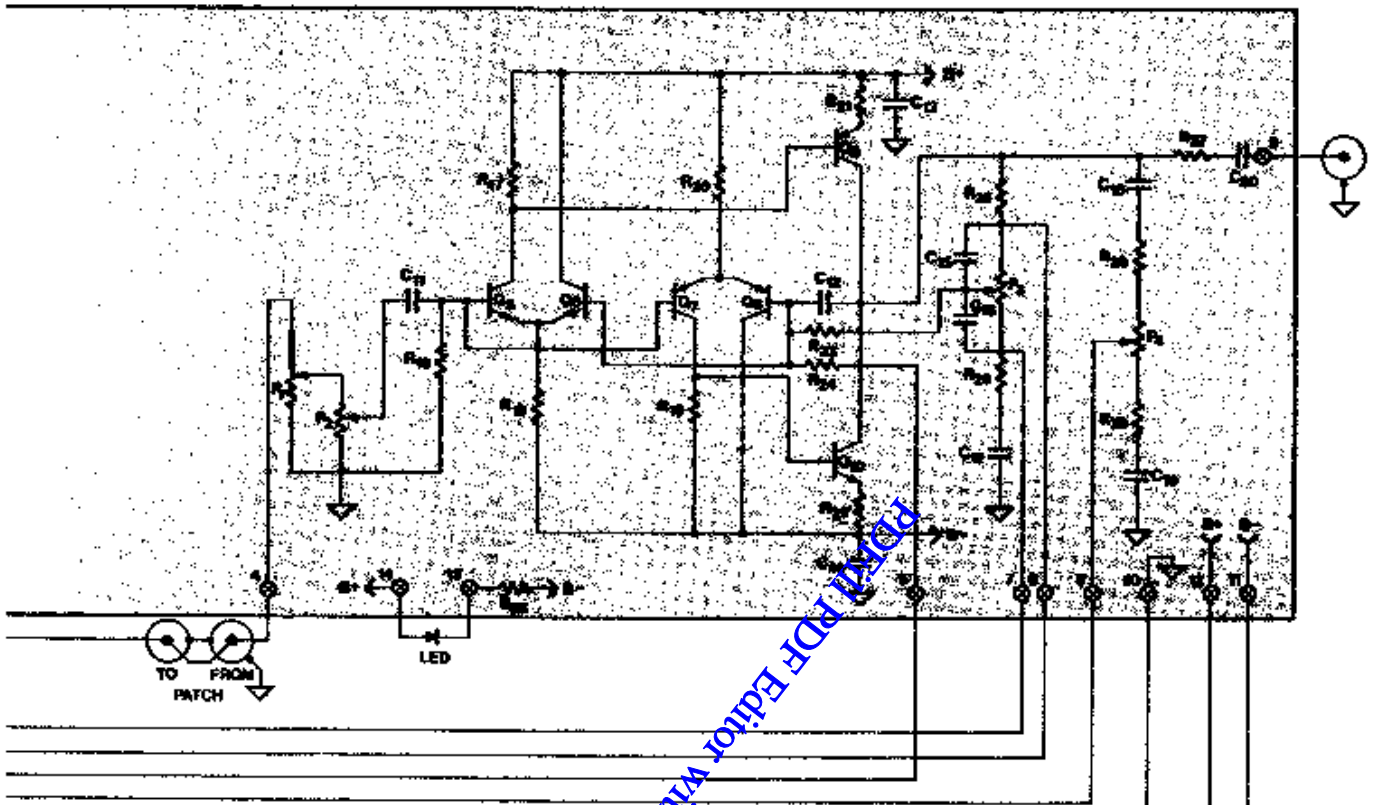

POWER SUPPLY SHOWN CONNECTED FOR 120 VOLTS.

ER

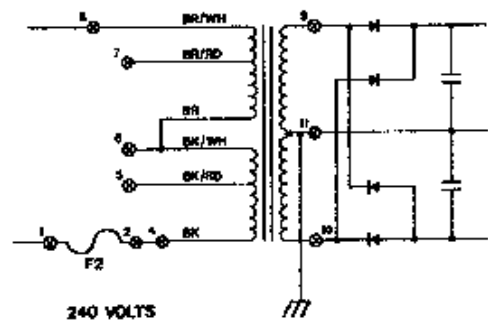
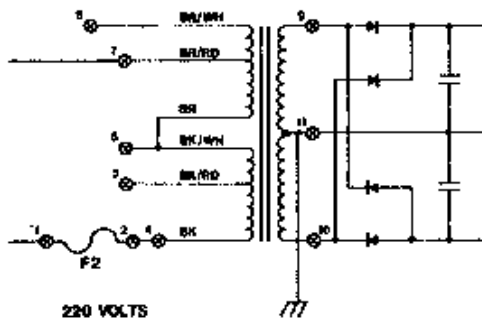

COMPONENT VALUES

All resistors are 1/2 Watt, 5% carbon film unless otherwise noted.

		Part No.			Part No.
R1	47,000 ohms	133473	C1	220 pF, 1000V, Disc	233221
R2	22,000 ohms	133223	C2	10 mfd, 3V, Tantalum	281106
R3	22,000 ohms	133223	C3	220 mfd, 6V, electrolytic	291227
R4	150,000 ohms	133154	C4	220 mfd, 6V, electrolytic	291227
R5	150,000 ohms	133154	C5	470 mfd, 16V, non-polarized, electrolytic	203477
R6	22,000 ohms	133223	C6	0.0068 mfd, 100V, Film	264682
R7	240 ohms \pm 2%	130241	C7	0.027 mfd, 100V, Film	264273
R8	22,000 ohms	133223	C8	10 mfd, 16V, non-polarized, electrolytic	203106
R9	10,000 ohms	133103	C9	22 pF, 1000V, Disc	238220
R10	100 ohms	133101	C10	22 pF, 1000V, Disc	238220
R11	100 ohms	133101	C11	10 mfd, 3V, Tantalum	281106
R12	470 ohms	133471	C12	15 pF, 1000V, Disc	238150
R13	11,000 ohms \pm 2%	130113	C13	0.1 mfd, 25V, Disc	233104
R14	130,000 ohms \pm 2%	130134	C14	0.1 mfd, 25V, Disc	233104
R15	100,000 ohms	133104	C15	0.043 mfd, 100V, Film	264433
R16	100,000 ohms	133104	C16	0.39 mfd, 100V, Film	264394
R17	22,000 ohms	133223	C17	220 mfd, 16V, non-polarized electrolytic	203227
R18	82,000 ohms	133823	C18	0.00135 mfd, 100V, Film	264132
R19	22,000 ohms	133223	C19	0.012 mfd, 100V, Film	264123
R20	82,000 ohms	133823	C20	10 mfd, 16V, non-polarized, electrolytic	203106
R21	100 ohms	133101	C21	0.01 mfd, 1000V, Disc	238103
R22	100 ohms	133101	C22	0.01 mfd, 1000V, Disc	238103
R23	10,000 ohms	133103	C23	0.01 mfd, 1000V, Disc	238103
R24	1,000 ohms	133102	C24	1000 μ F, 35V, electrolytic	293109
R25	10,000 ohms	133103	C25	1000 μ F, 35V, electrolytic	293109
R26	1,000 ohms	133102	C26	100 μ F, 25V, electrolytic	293108
R27	470 ohms	133471	C27	100 μ F, 25V, electrolytic	293108
R28	4,700 ohms	133472	C28	0.01 mfd, 1000V, Disc	238103
R29	1,000 ohms	133102	C29	0.1 mfd, 25V, Disc	233104
R30	1,000 ohms	133102	D1	Diode, 1N4002	544102
R31	1,000 ohms	133102	D2	Diode, 1N4002	544102
R32	2,700 ohms	133272	D3	Diode, 1N4002	544102
R33	2,700 ohms	133272	D4	Diode, 1N4002	544102
R34	10 megohms	133106	F1	Fuse 1/16A Slo-Blo 3AG	342060
R35	6,800 ohms	133682	F2	Fuse 1/32A Slo-Blo 3AG	342030
Q1	MPS-A-18	572001	P1, P2	Dual Balance/Volume Control	194001
Q2	MPS-A-6523	562001	P3	Bass Control	164001
Q3	MPS-A-65	562002	P4	Treble Control	164001
Q4	MPS-A-13	572002	T1	Power Transformer	464001
Q5	MPS-A-18	572001			
Q6	MPS-A-18	572001			
Q7	MPS-A-6523	562001			
Q8	MPS-A-6523	562001			
Q9	MPS-A-65	562002			
Q10	MPS-A-13	572002			
IC+	Positive Regulator MC7818CT	581001			
IC-	Negative Regulator MC7918CT	581002			

- 62 □ Select the Black/Red lead, trim it and connect it to eyelet #5. (S).
- 63 □ Select the Black lead, trim it and connect it to eyelet #4. (S).
- 64 □ Select the Brown lead, trim it and connect it to eyelet #2. (S). Make sure this eyelet and #4 are soldered to the circuitry.
- 65 □ Prepare a 4-1/2" red wire, and connect one end to eyelet #12. (S). Pass the other end through the grommet between the ICs.
- 66 □ Prepare a 6" green wire, and connect one end to eyelet #3. (S). Pass the other end through the same grommet.
- 67 □ Prepare a 7" black wire, and connect one end to the #11 eyelet nearest the front. (S). Pass the other end through the grommet.
- 68 □ Select the Red/Yellow transformer lead, trim it and connect it to the center larger eyelet #11. (S).
- 69 □ Select either of the two Red transformer leads, trim it and connect it to eyelet #10. (S). Trim and connect the other Red lead to eyelet #9. (S).
- 70 □ Select the main chassis assembly, two sheet metal screws, and the power supply assembly. Feed the short piece of power cord from the switch ST through the grommet in the brace adjacent to the transformer. The black wire from eyelet 5 of PC-3 should be placed behind the switches. Mount the brace to the side of the chassis with the two screws from the outside.
- 71 □ Select the back panel assembly and two sets of hardware. All of the long wires must now be bent toward you at the end of the socket strips, inside the two mounting holes to which the brace will be bolted. They will be sorted into an upper group and a lower group, so you may wish to untangle them now. Fasten the brace to the back panel with the screws from the outside. The back panel goes inside the main chassis sides.
- 72 □ Select four sheet metal screws and fasten the back panel to the chassis. Keep the loose wire ends close to the chassis to avoid any possibility of eye injury as you work.
- 73 □ Select the short piece of power cord, and connect the shorter end to AC outlet lug #3. (S-4). Connect the longer end to AC lug #2. (S-2).
- 74 □ Connect the short green wire from AC lug #6 to PC-1 eyelet #1. (S).
- 75 □ Connect the red wire from PC-1 eyelet 6 to AC lug

#1. (S-2). This wire is a little longer than necessary for 120 volt operation. It may be shortened if you wish. For other line voltages, the extra length may be needed.

- 76 □ Select the black wire from the switch assembly PC-3 eyelet 5, pass it through the side grommet in the brace, and connect it to an eyelet #11. (S).
- 77 □ Select the two shorter black wires which are not numbered, and are connected to back panel short lugs 10-11 and 21-22. Pass both of these through the grommet, and connect each to a separate eyelet #11. Solder both.
- 78 □ Place the two remaining shorter black unnumbered wires from back panel short lugs 0-1 and 0-12 inside the top and bottom edges, respectively, of the side of the chassis.
- 79 □ Select a plastic wire tie. This will secure the upper group of wires from the rear panel at the slots in the top rear of the brace. *Note:* These are self-locking, and must be cut apart, once engaged. Observe the detail diagram, and first think through the installation of each one to give the neatest appearance. The tie will not lock if it engages the latch from the wrong side. We suggest you pass the end of the tie first through the upper slot from the power supply side, around the wires, back through the lower slot, up through the latch. Pull it tight and cut off the excess.
- 80 □ Select another tie, and turn the chassis over. Secure the lower group of back panel wires at the rear, just as before, starting from the

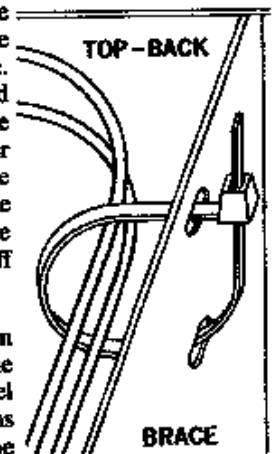

As the numbered wires are finally connected in the following steps, you may remove the tags, and if you wish, shorten some a bit for neatness. However, bear in mind that these lengths have been specified to conform to a clean, squared-off arrangement which will utilize several wire ties to hold bundles of wires in place. There are no critical locations for any wires. We have allowed for the most direct run using right angle bends at logical turns. Thus the wires run along the upper or lower edge of the brace, and then most of the lower wires turn upwards. Most of the wires pass along the top front of the brace before turning forward in line with the intended switch lug.

- 81 □ Select red wire #3 and connect it to SC lug #2. (S).
- 82 □ Connect green wire #14 to SC lug #5. (S).
- 83 □ Connect green wire #4 to SD lug #2. (S).

- 84 Connect red wire #15 to SD lug #5. (S).
- 85 Connect red wire #8 to PC-3 eyelet #1. (S).
- 86 Connect black wire #19 to eyelet #2. (S).
- 87 Connect green wire #7 to eyelet #3. (S).
- 88 Connect red wire #18 to eyelet #4. (S).
- 89 Connect red wire #6 to SE lug #4. (S-2). Be sure both wires are soldered to this and the following lugs. Take care to avoid burning insulation on adjacent wires.
- 90 Connect black wire #17 to SE lug #10. (S-2).
- 91 Connect black wire #5 to SE lug #1. (S-2).
- 92 Connect green wire #16 to SE lug #7. (S-2).
- 93 Turn the chassis over and connect red wire #10 to SR lug #3. (S). This, and the wire in the next step, actually should approach the switch from along the bottom of the brace, although the diagram must show it otherwise.
- 94 Connect green wire #21 to SR lug #9. (S).

FINAL WIRING

You are now in the home stretch. Even so, if you are tired, it is best to stop and come back to it later. Mistakes are most often the result of fatigue.

- 95 Select the PC-4 circuit board and three 3/8" nuts. If two of these are actually larger, it is because the volume control bushing requires it. Then include one of the larger ones as one of the three. Mount the circuit board to the front panel via the control shafts. The four remaining wires from the back panel, and the three wires from the grommet, will all be connected to the top of the board.
- 96 Connect the black wire from the grommet to PC-4 eyelet #10. (S).
- 97 Connect the green wire from the grommet to eyelet #11. (S).
- 98 Connect the red wire from the grommet to eyelet #12. (S).
- 99 Connect the green wire #9 to eyelet #9L. (S). This eyelet is in the front corner of the board. Do not confuse it with 9R. Eyelets 1 through 9 on PC-4 have either an L or an R identification, which must not be confused.
- 100 Connect red wire #20 to eyelet #9R. (S).
- 101 Place the green wire #11 alongside the brace to the front panel, and then under the lip at the front across

to the left front corner. Connect it to eyelet #4L. (S).

- 102 Place the red wire #22 alongside the lower edge of the brace to the front of the brace, then upwards to the top corner of the brace, forward to the front panel, and along the upper lip to the left to eyelet #4R. (S).
- 103 Place the black wire from short lug 0-12 on the back panel along the lower side lip of the chassis, and connect it to eyelet #2R. (S).
- 104 Place the black wire from short lug 0-1 along the top chassis lip, and connect it to eyelet #2L. (S).
- 105 Prepare a 12" green wire. Connect one end near the center of PC-4 to eyelet #3R. (S). Place this wire up and forward to the front panel, under the upper lip over to the switches, and connect the other end to SB lug #16. (S).
- 106 Prepare a 12" red wire and connect one end to eyelet #3L. (S). Place this wire also up and under the front lip, and connect it to SB lug #4. (S).
- 107 Cut two 1" pieces of the bare wire. These are to project above the PC-4 board at eyelets #13 and #14, to provide support for and connect the LED pilot lamp in the center of the panel. Solder the end of one wire to each eyelet, and see that they stick straight up.
- 108 Select the red LED lamp, and note that one lead is slightly shorter than the other. Cut an additional 1/16" off this lead, so you can easily identify the shorter one. Spread the leads to about the same spacing as the vertical wires on the board. The shorter lead connects to the eyelet #13 wire, which is nearest the switches. The tip of the lamp should project about 1/4" through the center of the round hole in the panel when the support wires are vertical. (With the finished front plate in position, the lamp will be held in place by spring tension from the supporting wires.) Solder the lamp leads to the supports. Here it helps to have a third hand — or some ingenuity with masking tape to hold the lamp. Failing that, tin the lamp leads, and the supports, and with the chassis upright on its side, melt a blob of solder on one support. Then connect the correct lamp lead temporarily to the solder. Now connect the other lead properly, and come back and remove the excess solder from the first. Be careful no solder splashes onto switches, etc.

In the following steps, since twisted groups of wires enter all switch lugs from the left, it is easiest to enter all lugs from the left as well, rather than always entering the lug from the outside of the switch. This helps to relieve strain on the lugs, but you must be careful to avoid bare wires touching any other than the intended terminal.

When soldering a wire to an eyelet from the bottom of the board, be sure to leave sufficient bare wire exposed so that a smooth solder flow can be observed from the wire to the circuitry.

109 □ Prepare three wires: a 13" black wire, a 19-1/2" red wire, and a 21" green wire. Start with the black wire and the green wire 3/4" longer than the red wire at one end, and twist all three together uniformly to within 1-1/2" of the other end of the black wire. This group is placed under the PC-4 board, and the twisted ends are brought up alongside the switches. Connect the red wire to SA lug #1. (S). Connect the green wire to SB lug #1. (S). Connect the black wire to SB lug #2. (S). At the other end, connect the black wire to the bottom of the circuit board at eyelet #1L. (S). Pass the green and red wires around the left side of the board, between eyelets 2L and 2R, to the upper lip on the side, and then back to the back panel. Connect the red wire to input socket lug #1. (S). Connect the green wire to input socket lug #2. (S).

110 □ Prepare three more wires: a 13" black wire, a 20-1/2" red wire, and a 19 1/2" green wire. Start with the red wire and the black wire 3/4" longer than the green wire at one end, and twist all 3 together uniformly to within 1" of the other end of the black wire. Place the group under PC-4, and the twisted ends up past the switches. Connect the green wire to SA lug #13. (S). Connect the red wire to SB lug #13. (S). Connect the black wire to SB lug #14. (S). Connect the other end of the black wire to eyelet #1R. (S). Place the green and red wires along the lower side lip, and back to the back panel. Connect the green wire to socket #12. (S). Connect the red wire to socket #13. (S).

111 □ Prepare an 8-1/2" red wire and an 11" black wire. Starting with one pair of ends even, twist these uniformly together to within 1-1/2" of the other end of the red wire. At the even ends, connect the red wire to SS lug #2. (S). Connect the corresponding end of the black wire to SS lug #3. (S). Place these wires along the lower front lip of the chassis, and connect the other end of the red wire to eyelet #8L. (S). Pass the black wire under the twisted groups, and connect it to eyelet #5L. (S).

112 □ Prepare a 7" green wire and a 9-1/2" black wire. Start with even ends, and twist these uniformly to within 1" of the other green end. At the even ends, connect the green wire to SS lug #8. (S). Connect the black wire to SS lug #9. (S). Place this pair along the bottom lip of the chassis, and connect the other end of the green wire to eyelet #8R. (S). Pass the black wire under the twisted groups, and connect it to eyelet #5R. (S).

113 □ Prepare an 8-1/2" black wire and an 11" green wire. Starting with even ends, twist these to within 1" of the other black end. At the even ends, connect the black wire to SS lug #4. (S). Connect the green wire to SS lug #5. (S). Place these wires behind the switches, and connect the other end of the black wire to eyelet #6L. (S). Connect the green wire to eyelet #7L. (S).

114 □ Prepare a 9" red wire and a 10-1/2" green wire. Starting with even ends, twist these to within 1" of the other red end. At the even ends, connect the red wire

to SS lug #10. (S). Connect the green wire to SS lug #11. (S). Place this pair behind the switches, and connect the other end of the red wire to eyelet #6R. (S). Connect the green wire to eyelet #7R. (S).

You have now completed the wiring. Look each connection over carefully, and make sure all are well soldered, and clear of adjacent terminals. Clip off any excess wire stubs — particularly on the switch lugs, so they cannot short across. Make sure there are no splashes of solder on the circuit boards that could cause a short circuit. If in doubt about a particular bridge, check the circuit pattern on the board layout found at the back of this manual. Now pick up the preamplifier and shake it well to dislodge any debris such as wire clippings.

Make the following specific checks:

- On the AC line cord (and the short piece of power cord to the switch) check that there are no loose strands.
- Make sure all AC outlet lugs are soldered.
- There should be no connection between input socket short lugs 1-2 and 2-3, or between 12-13 and 13-14. Also be sure the disc capacitor leads do not touch the long lugs, or the hardware.
- See that the bare ground wire woven between input socket short lugs does not contact one of the long lugs.
- Is the rear IC on PC-1 insulated with the mica washers and nylon screw?
- Are the leads of the disc capacitor on the power switch well clear of any metalwork, with the bottom installed? They should be short enough to prevent such an occurrence.
- Make sure no wires interfere with the motion of each pushbutton switch.

115 □ Select the remaining plastic wire ties. These are used to bundle the wires for a neat appearance, so precise location is not important. Slots are punched in the chassis and brace at some locations to anchor the ties. In other cases they are simply wrapped around the wires. When they pass through the chassis slots, be sure the joint is inside the chassis so it will not impede installation of the cover or front plate. The drawing shows intended tie locations.

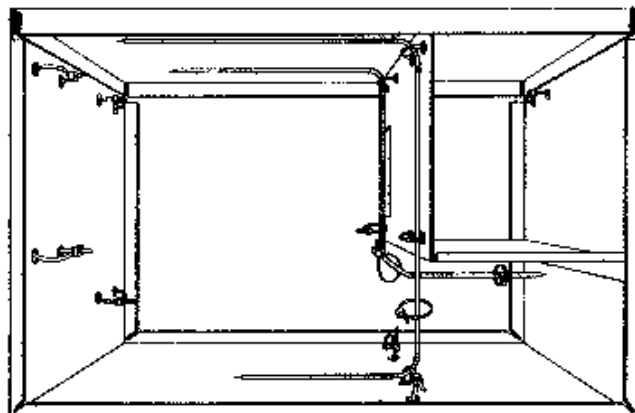

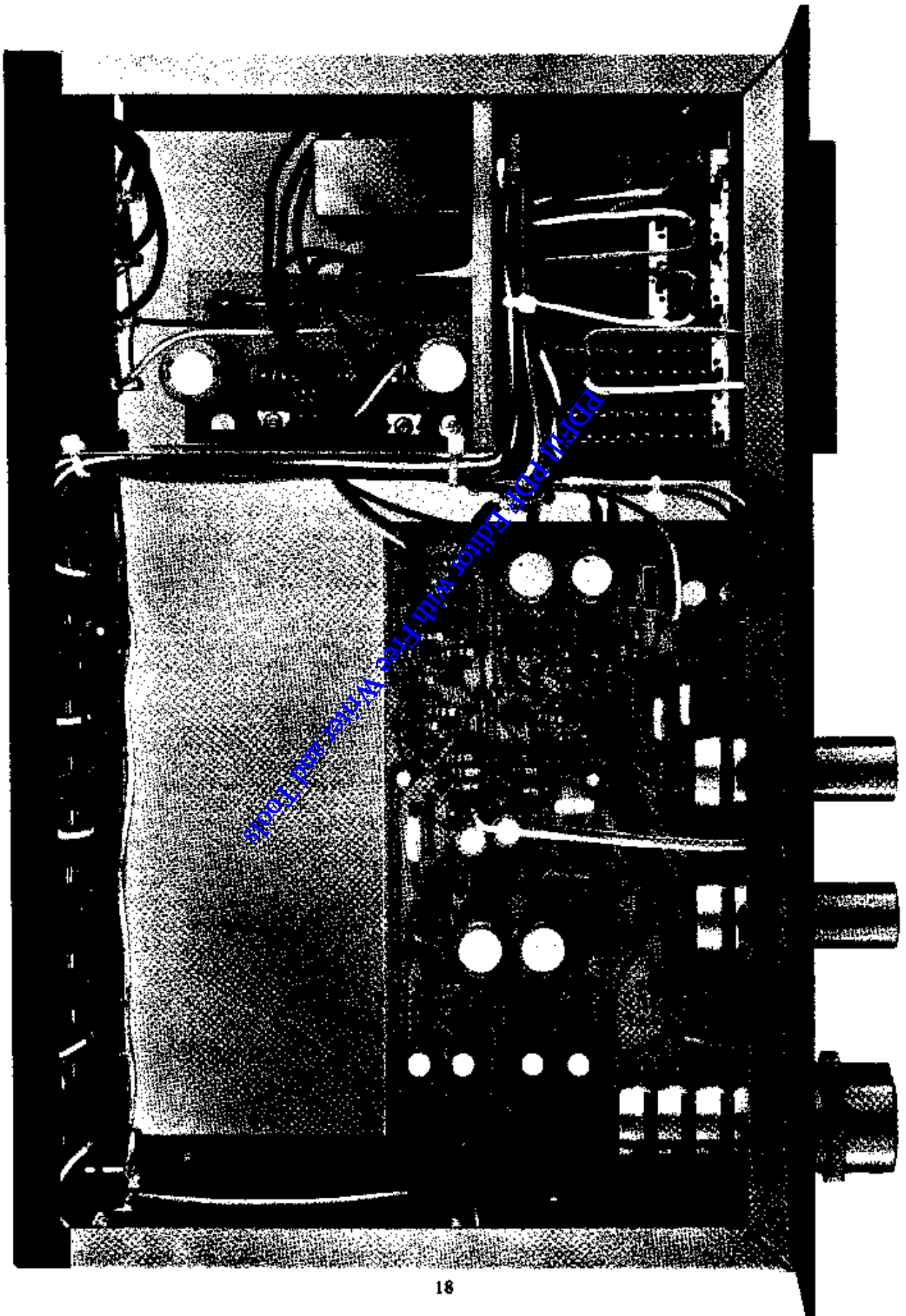

116 Cut two 3" pieces of the heavy solid wire. Bend each in a 3/4" wide rounded "U". Insert these in the sockets marked "Ext. Patch To and From" on each channel. Without this jumper (no outer ground connection is needed) the preamp will not work, unless an auxiliary unit, such as an equalizer, is connected to these sockets.

117 Select the 1/16 amp slo-blo fuse (1/32 amp for 220 or 240 volt use) and install it in the fuse clips on PC-1. Support the board from below to avoid damage.

Now make sure wires along the lower chassis lips do not obstruct holes through which the screws to secure the cover and bottom plate will be installed. Particularly note the center hole in the back panel.

118 Select the bottom plate and six sheet metal screws, and install it so that the feet are placed toward the rear of the unit.

119 Select the black front plate and three 3/8" (or larger) nuts. Remove the nut from the stud, and install the plate, positioning the LED lamp snugly in the hole. If necessary, loosen the control nuts to reposition them slightly. Check to see that the switches don't bind, and tighten the three control nuts. *Do not tighten the nut on the stud more than finger tight. Excessive force will cause the front plate to bend.*

120 Select the cover and the four black sheet metal screws. If you are using a screwdriver, instead of a 1/4" nut driver to install the sheet metal screws, you may wish to pre-cut threads in the side holes, by temporarily inserting the screws before the cover is installed. This minimizes the risk of scratching the cover on completion. Make sure no wires will be pinched on top of the brace, (especially near the transformer mounting hardware), and install the cover.

121 Select the knobs and the Allen wrench. Install the thin Balance knob on the larger shaft at the left of the panel, with the narrower diameter next to the panel. Tighten the set screw so that rotation is symmetrical about the center. Install the large knob in front of it on the smaller shaft, so that its counterclockwise limit is at 7 o'clock. Install the two tone control knobs so that each can rotate symmetrically from the center "flat" indicator on the panel.

122 Remove the backing from the serial number label, and install it at the center rear of the bottom plate.

Save the Allen wrench for the knobs. You may wish to simply secure it to the bottom plate with masking tape.

YOUR COMPLETED KIT SHOULD BE NEAT, AND LOOK MUCH LIKE THESE PHOTOS. CONGRATULATIONS!

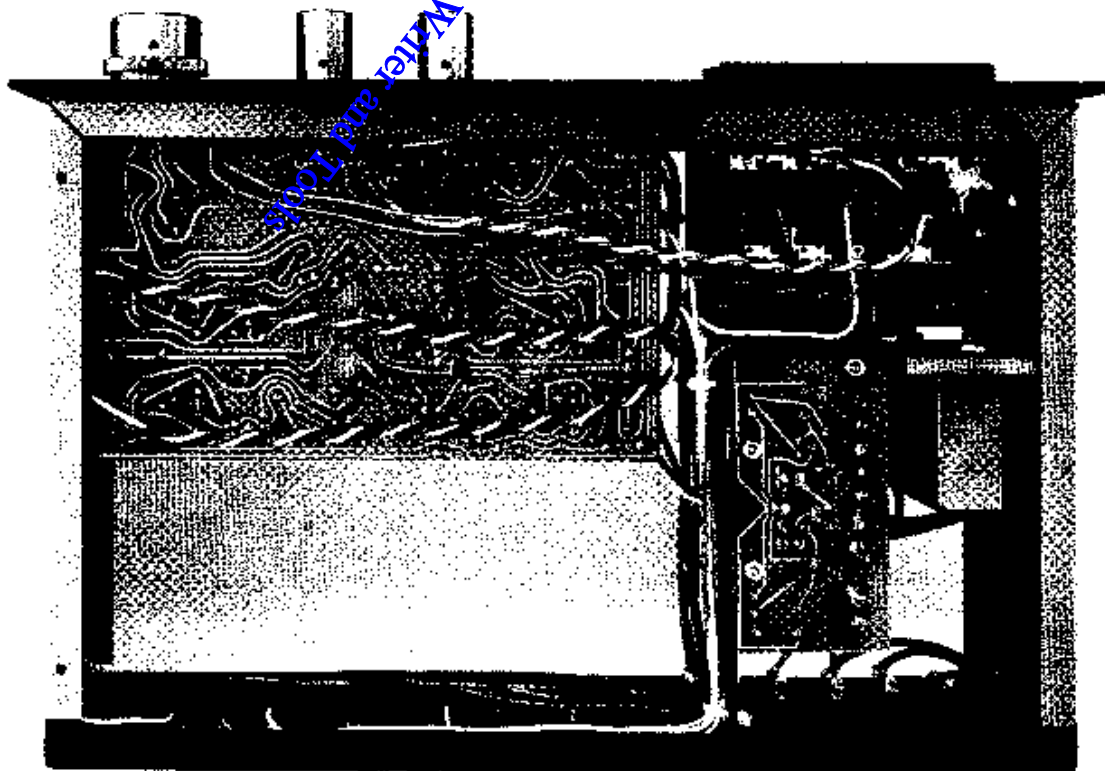

IF PROBLEMS ARISE

Before shipment from the factory, the circuit boards containing active components in each DH-101 kit are given a thorough electrical checkout to assure conformity with the published specifications. Factory wired preamplifiers not only receive separate circuit board checks, but each completed unit is thoroughly tested for conformance as well. Therefore, if a problem arises in use, first check the connections between the different components in the system before assuming the preamplifier to be at fault. Be sure the interconnections agree with the installation instructions. Check that each "U" jumper is installed between *From* and *To External Patch* connections on the rear panel. Be sure that neither the *Tape 1* nor *Tape 2* buttons are depressed unless you are playing a signal from a tape recorder.

If neither channel works with any program source (Phono, Tuner, Auxiliary or Tape) it is highly unlikely that all sources would be faulty. Temporarily bypass the preamplifier by connecting from one of the high level input sources (Tuner, Auxiliary or Tape) directly to the amplifier inputs. Use the volume control on the amplifier or input source. If the system works, then the fault is in the preamplifier or its associated cables. If the system still does not work, then the fault is most likely in the power amplifier, speakers, or speaker wiring.

If the LED pilot lamp does not light, this may indicate a blown fuse in the preamp. The fuse is located on the power supply circuit board. Always replace with the same size fuse. If a second fuse blows, look for a problem in the preamplifier power supply section.

A fault in only one channel suggests interchanging channels to determine the location of the problem. This can be accomplished by interchanging the appropriate cables. If the fault switches channels when the cables are interchanged at one end, then the fault is located prior to the interchange point in the signal path. If it remains on the same channel as before, the fault is after the cable switch point. If you make a complete cable interchange at both ends simultaneously, and the fault changes channels, the problem is in the one cable.

Most of the difficulties which are encountered in kit built units can be attributed to incorrect wiring, or to poor solder connections. It is suggested that you ask someone else to check your work against the Pictorial Diagram, for often one person will tend to make the same mistake in checking as he did in building the unit.

When servicing your preamplifier we recommend you:

1. Never make circuit changes of any kind without first disconnecting the AC line cord from the wall. ALWAYS EXERCISE EXTREME CAUTION WHENEVER THE COVER OR BOTTOM PLATE IS REMOVED!
2. Be very careful to never short any transistor leads to the chassis, the power supply voltages, or to each other when power is applied.
3. Be careful to use the least amount of heat necessary when unsoldering or soldering transistors, diodes or other semiconductors.

Locating a Fault

Phono signals connected to the Phono 1 and Phono 2 inputs of the DH-101 are equalized by the phono preamplifier and then routed by the selector switch and control circuitry to the tone/output amplifier. All high level signals (Tuner, Aux, Tape) connect directly to the control circuitry and

tone/output amplifier via the selector switches. A difficulty can therefore be pin-pointed to one or the other channel and then to the low level (Phono) or high level sections.

For example, if only the right channel plays in the Phono mode, yet both channels play in the Tuner mode, then we can deduce that the fault exists in the left phono section. This can be verified by taking signals from the Tape Outputs into the power amplifier directly (if the power amplifier has an input level control). This technique bypasses the tone/output amplifiers.

If there is no output under any conditions from the left channel, then we can deduce that the fault probably lies in the left tone/output amplifier.

Hum and Noise

The DH-101 is inherently hum free, and hiss is at the low levels associated with state of the art designs. Therefore hum and/or hiss should only be heard when the volume control is rotated way beyond normally loud listening levels.

If hum is heard on both channels when the volume control is turned down (full CCW), then suspect that either or both of the power supply IC regulators may be shorted from input to output.

Hum in the phono channels usually indicates a ground problem in connections between preamp and turntable. Try connecting a ground wire between the turntable chassis and the ground screw on the DH-101. Alternately, if the turntable is already grounded, try disconnecting that ground. Sometimes it is necessary to experiment with interconnecting grounds between differing pieces of equipment, and with a separate "earth" ground to a water pipe. Use the fewest number of ground interconnections that accomplishes the purpose. Some types of interference require separate ground connections; in other cases it raises the noise level.

Phono Preamplifier

If there is a malfunction in the phono preamplifier, the chances are that the malfunction is caused by a shorted or open electrolytic capacitor (very rare), failure of Q3 or Q4 (almost as rare) or failure of Q1 or Q2 (more likely). Substitution with transistors known to be good (such as from the other channel) is the best diagnostic technique. First be certain that no external cause would induce failure in the replacement transistor, however.

High Level Amplifier

Malfunction of the high level tone/output amplifier will almost always be caused by transistor failure. The most likely culprits are Q5 and Q7. Substitution is the easiest test.

Power Supply

The power supply consists of a full wave bridge rectifier circuit filtered by a series pair of 1000 μ f capacitors, followed by an IC regulator. With normal line voltage, the DC voltage across each of the 1000 μ f filters should be 29 volts, and the peak to peak ripple should be 0.2 volts. The DC voltage at the output of the regulators should be 18 ± 1.6 volts, and the ripple and noise should be below 2mv peak to peak. The integrated circuit voltage regulators are short circuit protected and simply turn off if their outputs are shorted. When the short is cleared, they resume normal operation. The power supply is substantially overdesigned in order to accommodate extreme line voltage variations, temperature extremes, and the inclusion of the optional preamplifier. Thus the likelihood of malfunction is remote.

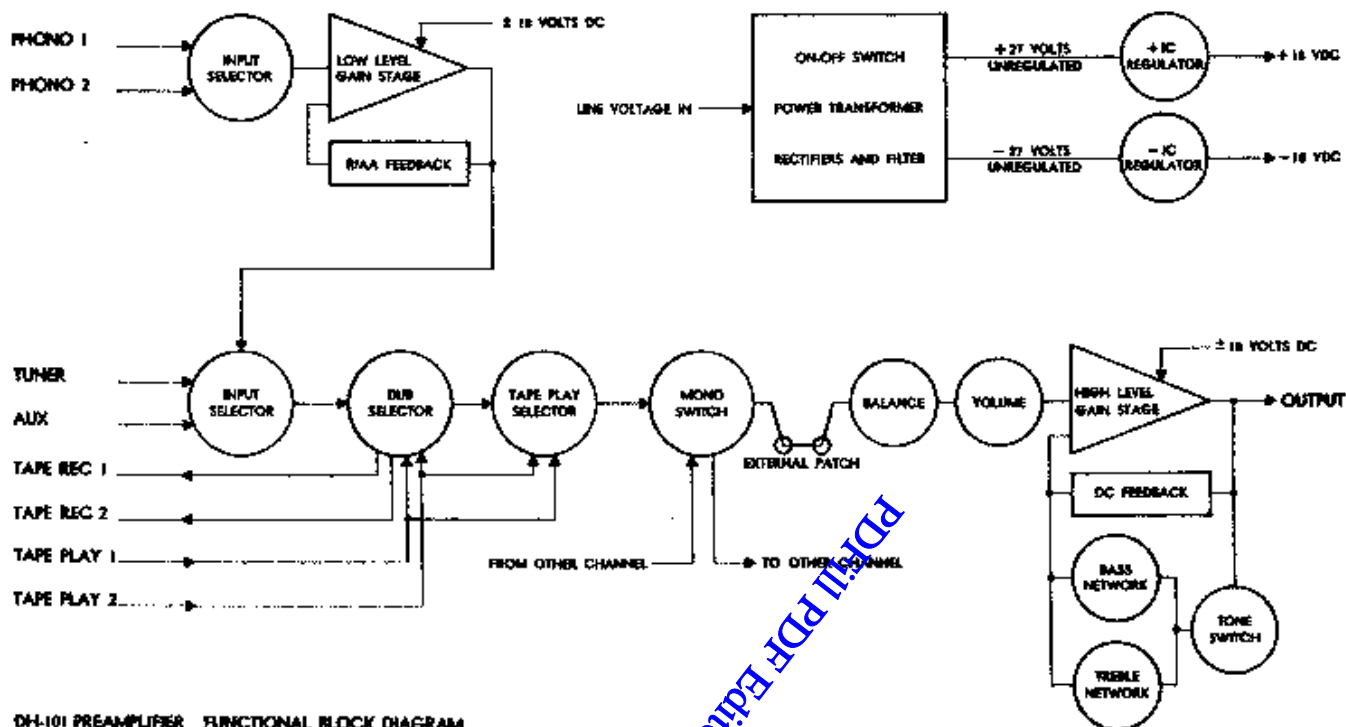

DH-101 PREAMPLIFIER FUNCTIONAL BLOCK DIAGRAM

CIRCUIT DESCRIPTION

The DH-101 preamplifier consists of four sections (or five when the optional moving coil cartridge head amplifier or pre-preamplifier is installed). These are the power supply, the phono preamplifier, the tone control output amplifier and the switching circuits.

The power supply is designed to deliver regulated ± 18 volt DC current over a line voltage variation of 105 to 130 volts. Similar line voltage variations can be accommodated when the unit is connected for operation on nominal 100, 220 or 240 volt lines. The circuit is conventional in that it uses a transformer for stepping down the line voltage to the required level. Rectification is accomplished in a capacitor input type filter. Regulation and additional filtering is performed by heat sunk IC regulators.

Both the preamplifier and the tone control output amplifier utilize all push-pull complementary pair type amplifiers. The preamplifier version is arranged so that the feedback is returned to the emitters, to minimize emitter impedance and its associated noise. The output amplifier utilizes a complementary differential amplifier input arrangement to provide high impedance inputs for both the feedback and input signals. The complementary all push-pull design is what gives these circuits such outstanding pulse and transient response characteristics and low distortion.

The phono amplifiers consist of two stages with a feedback loop around both stages. The required equalization for record playback is incorporated in this feedback loop. Particular attention was paid in this design to having adequate driving signal into the low impedance of the feedback loop. In this way, the phono section can deliver very high signal

outputs at all frequencies, including those above the audio range. As a consequence, the acceptance level of the unit increases with frequency, so that high frequency transient signals (clicks and pops, etc.) will not tend to overload the audio range.

The circuit arrangement maintains a constant input impedance at all frequencies of interest, to avoid problems of undesired cartridge interaction.

As mentioned in the Installation section, the DH-101 has an input capacitance of about 30 pF, plus a 220 pF phono input capacitor. This capacitor is shown as C1 in the schematic diagram, the circuit board diagram, and the pictorial diagram. If your cartridge requires minimal capacity, C1 can be removed, or it can be changed if your cartridge requires a different value of capacitive load. Remember to include the capacitance of the turntable leads when determining the proper value of capacitor to load your cartridge.

The tone control amplifier is also a feedback pair of stages, and the control action is derived by the addition or subtraction of feedback at the extremes.

The switching circuits are conventional, although the use of precision push button selector switching is unique in a design which is supplied in kit form, as well as fully assembled.

Outputs to tape recorders and to external units to be patched in are buffered through 1,000 ohm resistors so that the input loading of associated equipment does not act as a burden on the preamplifier circuitry.

SERVICE POLICY AND LIMITED WARRANTY

The DH-101 Preamplifier has been carefully engineered to provide many years of use without requiring any maintenance or servicing.

Factory assembled units are subjected to a battery of physical and electrical tests before shipment. The circuit board assemblies of kit units are similarly tested prior to shipment. In spite of all this testing, shipping damage does occur, kits are not assembled properly or someone "goofs" and service and/or maintenance will be required. The David Hafler Co. provides complete service facilities at the factory to make any necessary repairs.

It is the owner's responsibility to return or ship the unit freight prepaid to the factory service department. Units shipped freight collect will not be accepted. For units to be repaired under warranty a dated bill of sale must accompany the unit.

Shipment should be made via UNITED PARCEL SERVICE. Parcel Post is not a safe way to ship electronic equipment. The factory will not be responsible for damage caused by parcel post shipment and repairs will be made at the owner's expense. When shipping your DH-101 be sure to insure it for the full value of a wired unit.

Use the original carton and packing material to ship your preamplifier. Enclose with the unit the following information:

1. Complete shipping address (Post Office box numbers are not acceptable).
2. The serial number.
3. Copy of dated bill of sale if repairs are to be made under warranty.
4. Description of the malfunction. If intermittent, please note.
5. We also suggest further identifying the unit as yours by putting a label on the bottom or tying a label with your name and address on the line cord.

All service work is guaranteed for 90 days.

Warranties apply to the original purchaser only. Warranties are void if:

1. The preamp has been either physically or electrically abused or used for some purpose for which it was not designed.
2. The preamp has been modified without factory authorization.

The transformer warranty is void if the leads have been cut too short for reuse. If you think a transformer is defective the leads must be unsoldered, not cut for its return.

Technical assistance to help you locate the source of a problem may be obtained by writing the Technical Services Department. It is helpful to know the serial number of the unit and the results of any tests you have performed.

WARRANTY FOR KIT-BUILT UNITS

The parts in a DH-101 kit are warranted for a full year from the purchase date. If a defective component is found on a circuit board or in a kit, simply return the *individual* part to the factory prepaid together with the serial number and the date of purchase, and it will be replaced at no charge.

If you cannot locate what is wrong with your DH-101, return it to the factory along with a copy of the dated bill of sale and a check for \$25. If the difficulty is a defective part, the unit will be returned prepaid to you and your \$25 *less the shipping charges* will be returned to you. If the problem is found to be an error in your assembly of the unit, the unit will be put in proper working order and then returned to you (freight prepaid within continental U.S.).

This warranty is void if the kit has not been completely assembled or if other than rosin core solder has been used. Units assembled with acid core solder or paste flux will be returned unserviced.

WARRANTY FOR FACTORY ASSEMBLED UNITS

The DH-101 is warranted for a full year from the purchase date including parts and labor and shipping costs from the factory to the owner within the continental U.S. The owner is responsible for returning the unit to the factory and must submit a copy of the dated bill of sale.

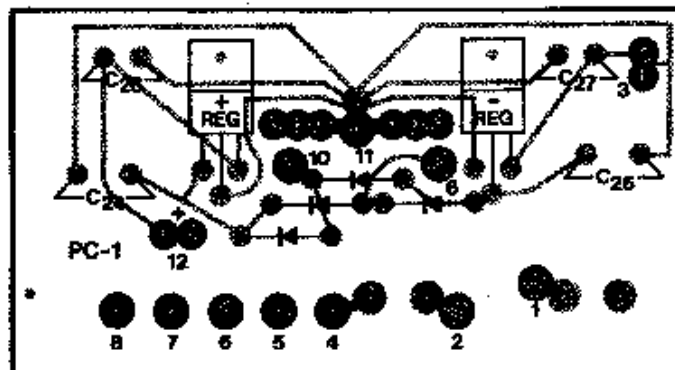

KIT PARTS LIST

Minor variations may sometimes be encountered in value or appearance. These will not affect performance.

Delicate Items Envelope

	Part No.
1 Fuse, 1/16 ampere, slo-blo or 1/32 ampere, slo-blo (230v)	342060 342030
1 LED pilot lamp, red	596001
1 Toothpick, wooden, round	865001
1 Washer, mica, rectangular	696001
1 Washer, mica, round	696002

Hardware Envelope

	Part No.
4 Feet, rubber	859001
2 Grommet, rubber	855001
2 Lug, solder terminal	619308
21 Nut, #4-40 KEP	614245
8 Nut, #6-32 KEP (one on panel)	614345
6 Nut, 3/8"	624081
or 2 of these may be larger	624091
1 Nut, knurled round thumb type	625365
24 Screw, #4-40 x 5/16"	611255
5 Screw, #6-32 x 1/2"	611385
16 Screw, #6 sheet metal thread	612345
4 Screw, #6 sheet metal, black	612347
1 Screw, #4 nylon plastic, 3/8"	691261
4 Set Screw, Allen #6	613827
1 Strain Relief, plastic	895001
1 Wrench, "L" shape, Allen #6	968001

1 Chassis, "U" shape	711001
1 Brace, "L" shape	711002
1 Switch Mounting Bracket	711003
1 Back Panel, black	711004
1 Bottom Plate	711005
1 Cover, black	711006
1 Front Plate, black anodized	761001
2 Knob, tone control	764001
1 Knob, balance control	764002
1 Knob, volume control	764003
1 PC-1 Circuit Board Assembly	993001
1 PC-2 Switch Board Assembly	993002
1 PC-3 Switch Board Assembly	993003
1 PC-4 Circuit Board Assembly	993004
4 AC outlet	351001
1 Cable pair, audio	322072
4 Capacitor, disc, .01 μ f @ 1000v.	238103
2 Capacitor, disc, .1 μ f @ 25v.	233104
2 Input socket strips, 11 position	351101
1 Label, serial number	808001
1 Label Set, numbered wire tags	808100
1 Line cord, with plug	322001
1 Power cord section, 10"	322002
1 Transformer, power	464001
15 Wire Ties, plastic	894001
1 Wire, black #22	
1 Wire, green #22	
1 Wire, red #22	
1 Wire, bare solid #22, 27"	310003
1 Wire, bare solid #8, 6"	310001
1 Registration card	

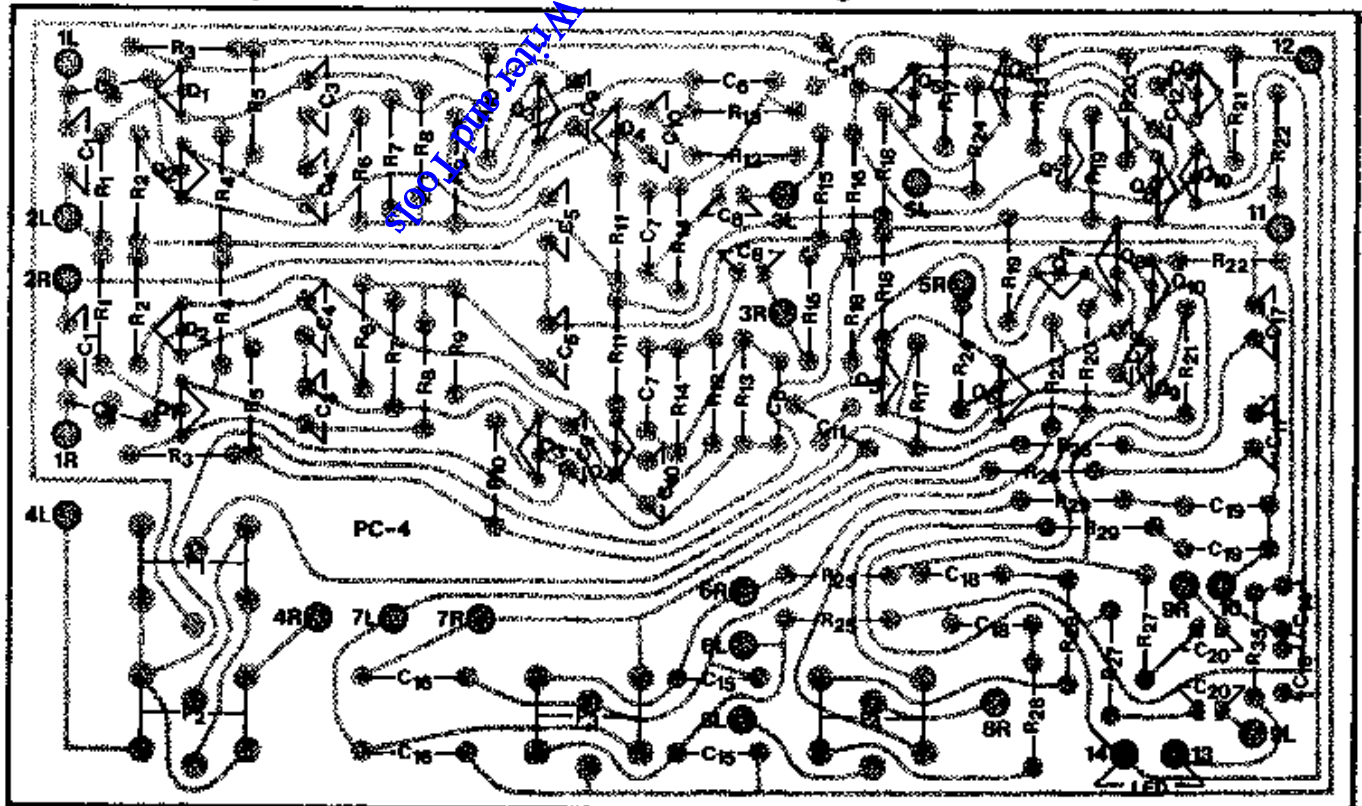

SPECIFICATIONS

PHONO PREAMP SECTION

Type: Discrete transistor (no integrated circuits)

Rated output: 3 volts, 10 Hz to 100 kHz

Maximum output: 7 volts, 20 Hz to 20 kHz

Total Harmonic Distortion: Less than .0006% @ 1 kHz and 3 volts out

Slew rate: 12 volts per microsecond

Phono overload: 180 mV @ 1 kHz; 1.8V @ 20 kHz

Phono cartridge interaction at 20 kHz: unmeasurable

Hum and noise: "A" weighted 86 dB below 10 mV, 1 kHz input

Frequency response: Complies with RIAA specification 40 Hz to 15 kHz \pm 0.5 dB

Hi-pass filter: In accordance with proposed RIAA revision

(IEC publication 98, Amendment No. 4, Sept 1976)

Gain: 34 dB @ 1kHz

Input impedance: 47 k Ω in parallel with 250 pf*

*Input capacity can be modified to conform with cartridge requirements. Above value must be added to capacity of connecting cables to determine total cartridge load.

TONE CONTROL SECTION AND HIGH LEVEL AMPLIFIER

Type: Discrete transistor (no integrated circuits)

Rated output: 3 volts, 10 Hz to 100 kHz

Maximum output: 7 volts, 10 Hz to 100 kHz

Total Harmonic Distortion: Less than .001% 20 Hz to 20 kHz at rated output

Slew rate: 12 volts per microsecond

Rise time: 2 microseconds

Hum and noise: "A" weighted: 90 dB below 1 volt

Frequency response: +0.0, -0.25 dB, 20 Hz to 20 kHz

Gain: 20 dB \pm 1 dB

Input impedance: Greater than 25 k Ω

Bass control: Type: Moving inflection with variable turnover frequency.

Amount: \pm 12 dB @ 50 Hz

Treble control: Type: Shelving with fixed turnover frequency.

Amount: \pm 10 dB @ 20 kHz

GENERAL SPECIFICATIONS

Number of semi-conductors: 28 transistors, 2 integrated circuit power supply regulators, 4 diodes, 1 LED

Inputs: Two phono, tuner, auxiliary, two tape recorders

Outputs: Two tape (buffered) and one program

Provision for patching in external equipment

Controls: Volume, balance, bass, treble, tape dubbing, input switching, mono-stereo, tone control engage, power on-off

Intermodulation distortion: At normal levels of operation, IMD, whether SMPTE or CCIF, from phono input to preamplifier output is below the residual of currently available instruments

AC voltage: 100/120/200/220/240, 50/60 Hz

Power consumption: 3.5 watts

AC convenience outlets: 2 switched, 5 amp continuous, 7.2 amp surge;
2 unswitched, 5 amp continuous

Designed to requirements of Underwriter Laboratories Specification UL-1270

Size: 13.75" wide x 3.25" high x 8.5" deep (35 x 8.25 x 21.5 cm).

Knobs project 1" (2.5 cm)

Shipping weight: 9 lbs. (4 Kg)

Net weight: 8 lbs. (3.6 Kg)

All specifications are subject to change without notice.